

Split Spherical Roller Bearings

Super-fast bearing replacement in hard-to-reach places

Easy on/easy off = less downtime!

Split FAG spherical roller bearings allow bearings to be replaced in no time. Compared to standard (solid) bearings, split bearings can be replaced in just a few steps.

Split bearings offer the following advantages:

- Easy installation and removal
- Drive components do not need to be removed
- Shafts do not need to be dismantled or aligned
- Increased plant availability
- Significant savings, thanks to shorter downtimes



Exploded view of an FAG split spherical roller bearing with split solid cage made from glass fiber reinforced polyamide or brass; integrated locking rings

Reduced bearing replacement costs

Choosing FAG split spherical roller bearings reduces machinery and equipment downtime, which significantly lowers installation costs. In addition, new designs can take advantage of simplified layouts and lower labor costs.

Cost comparison: standard vs. split bearing

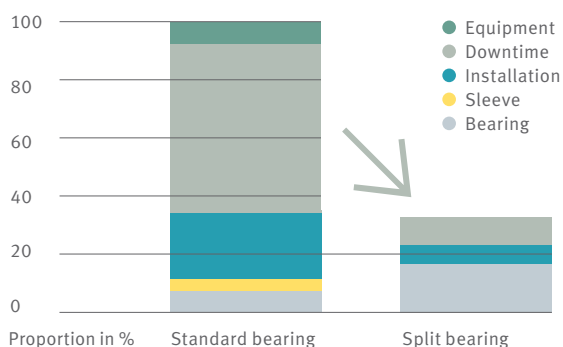

Compatible with existing plummer block housings

FAG split spherical roller bearings are a direct replacement and compatible with all plummer block housings (even from other manufacturers, provided that the internal dimensions are identical) – no modifications to the housing required!

No adapter sleeves required

Unlike standard spherical roller bearings that use adapter sleeves, FAG split spherical roller bearings are easily installed directly on the shaft. Outside diameter, outer ring width and shaft seat diameter remain unchanged.

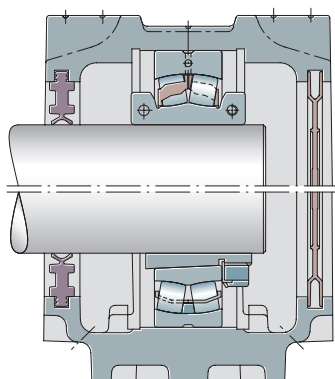

Because split spherical roller bearings utilize the same installation space as their standard counterparts, replacing spherical roller bearings is no longer a problem.

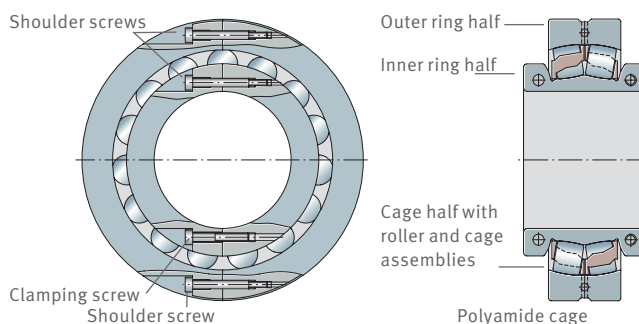

Optimum load-carrying capacity: The internal design of the bearings with integrated locking rings.

Comprehensive product portfolio and design

FAG split spherical roller bearings are available for metric shafts ranging from 55 mm to 630 mm in diameter as well as inch shafts ranging from 2³/₁₆ inch to 16 inches in diameter.

And less downtime = substantial savings for you!

Fewer work steps – more savings

Comparison of typical bearing-replacement steps (e.g., in a compressor)	Standard Bearing	Split Bearing
Disconnect drive (gearbox/belt/chain/electric motor)	✓	
Remove coupling halves/drums/turas gearbox	✓	
Support the weight of the shaft unit/rotor		✓
Remove upper part of housing	✓	✓
Lift shaft unit/rotor out of the housing	✓	
Remove lower part of housing	✓	
Remove and replace bearing	✓	✓
Assemble shaft unit/rotor and lower part of housing	✓	
Align shaft line and lower part of housing	✓	
Secure lower part of housing to foundations	✓	
Fit upper part of housing	✓	✓
Fit drive components	✓	✓
Connect and align drive	✓	

Cost-effective solutions for many applications

FAG split spherical roller bearings deliver exceptional quality in accordance with Schaeffler's stringent standards – across all market sectors as well as for customer-specific solutions.

Overview of features

- Inner ring, outer ring, and cage segments are split
- Cylindrical bore, mounts directly on the shaft
- Same dimensions as standard spherical roller bearings with adapter sleeves
- Compatible with existing split plummer block housings
- Dynamic self-alignment capability
- Suitable for high- and variable temperature environments

Application example – Mining

A leading global mining company installed its first FAG split spherical roller bearing in a conveyor system.

- The result: Downtime due to bearing replacement was reduced from 22 hours to 3 hours.
- The savings: Approximately 180,000 USD



FAG split spherical roller bearing installed in a conveyor system

Application example – Steel

Schaeffler's field service engineers replaced two (standard) support bearings with split spherical roller bearings in a steel converter at Tata Steel in England.

- The result: Total costs were significantly reduced, primarily due to the customer-specific solution's shorter downtimes.
- The savings: Approximately 208,000 USD



Installing an FAG split spherical roller bearing in a steel converter

**Schaeffler Technologies
AG & Co. KG**

Georg-Schaefer-Strasse 30
97421 Schweinfurt
Germany
Internet www.schaeffler.com
E-mail info.de@schaeffler.com

In Germany:

Phone 0180 5003872
Fax 0180 5003873

From other countries:

Phone +49 9721 91-0
Fax +49 9721 91-3435

Every care has been taken to ensure the correctness of the information contained in this publication but no liability can be accepted for any errors or omissions. We reserve the right to make technical changes.

© Schaeffler Technologies AG & Co. KG
Issued: 2020, November
This publication or parts thereof may not be reproduced without our permission.