

We pioneer motion

Linear recirculating roller bearing and guideway assemblies

6th generation RUE-F



Pioneering work for more than 50 years

After five decades in the sector, Schaeffler has outstanding expertise in the field of rolling bearing solutions for production machinery and automation technology that is hardly matched by any other company. With our innovative new developments, we are continuously helping our customers to overcome technical limits.

We are also pioneers in the field of monorail guidance systems. We presented the first linear guidance systems that were supported by rolling elements as early as the 1960s, a decade that was characterized by a constant striving for technological progress: The PR linear recirculating roller bearing in 1965 was followed by the RUS linear recirculating roller bearing in 1969, the year in which Neil Armstrong became the first man to step on the moon.

Since 1988, we have been setting the benchmark in terms of the highest rigidity, load carrying capacity, precision, and reliability with our RUE linear recirculating roller bearing and guideway assemblies – particularly in the machine tool sector. The fifth generation has now been successfully established on the market since 2003 – for example, in press construction, in straightening machines or in giant milling and gantry machines. With the “RUE”, we have left our own, unmistakable footprint in the machine tool sector. Accordingly, we set the bar high for the sixth generation RUE-F, which we are presenting in a brief overview here.

If shorter assembly times, lower operating costs, and a longer operating life are decisive arguments for you, there is no need to look any further than our new development. The upgrade to the new RUE-F pays off – as original equipment or as a retrofit – for machine manufacturers and machine operators in equal measure.



1965

First roller guidance system with rolling element guidance – PR linear recirculating roller bearing

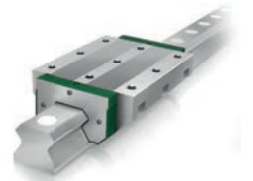

2003

First RUE linear recirculating roller bearing and guideway assembly of size 100



2020

First Industry 4.0 solution for monorail guidance systems

SAVE LUBRICANT WITH EVERY METER

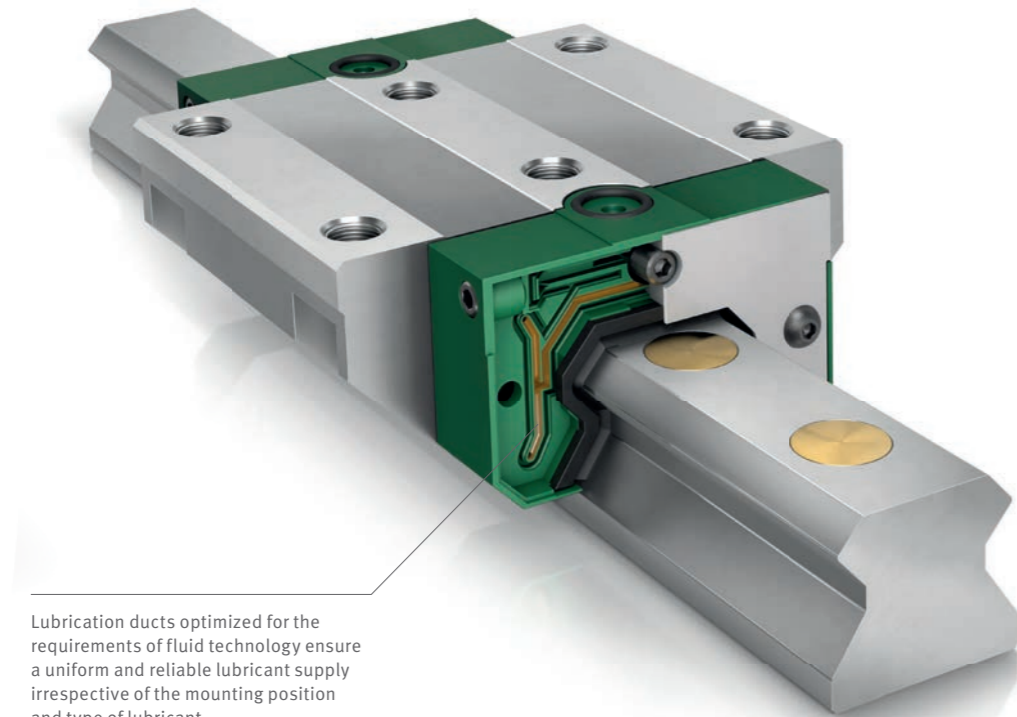

Lubrication ducts optimized for the requirements of fluid technology ensure a uniform and reliable lubricant supply irrespective of the mounting position and type of lubricant

Lower operating costs – clean machines

A reduction in the quantity of lubricant reduces the operating material costs and protects the environment. This is particularly relevant for machine tools with regard to cooling lubricant contamination. The challenge: The smaller the metered amount of lubricant, the more precisely the lubricant must be distributed to all the rolling contacts. Our engineers have solved precisely this challenge. By means of an innovative lubrication duct design with optimized flow, we can achieve a perfect distribution of the lubricant to all four

raceways – irrespective of the mounting position of the carriages and regardless of whether you use grease or oil in your machines. In addition, the rolling elements are supplied with lubricant in a targeted manner before they enter the load zone – the critical moment. The correct function of RUE-F monorail guidance systems is also ensured with very small metering quantities. The operational reliability and the operating life of your machine are increased due to the favorable tribological conditions.

Factsheet

- Lubricant requirement is reduced by up to 50%
- Risk of insufficient lubrication is minimized
- Can be used for grease and oil lubrication
- Optimum lubrication in all mounting positions
- Longer operating life
- Reduced cleaning and maintenance outlay
- Increased operational reliability

FOR NOTICEABLY SMOOTHER RUNNING



The linear guidance system influences workpiece quality

The important quality characteristics of a monorail guidance system with rolling elements include the displacement force, the fluctuation in the displacement force, and the stroke pulsation due to the entry and exit of the rolling elements. A rolling element recirculation system that is well designed in terms of kinematics has a positive influence on these values. The optimization of the rolling element recirculation system reduces the excitation (micromotion) of the machine structure. This is a decisive factor for the high surface qualities of machining centers. The rolling element recirculation system also has a direct influence on the displace-

ment forces and thus the energy consumption of the drives. We have completely redesigned the rolling element recirculation system in order to make a significant leap forward in development in the sixth generation "RUE". Our engineers have achieved a very robust recirculation and a smooth entry of the rolling elements into the load zone through the use of an innovative material and an optimized internal design. These design details result in significantly lower displacement forces and fluctuations in the displacement force. With the new RUE-F, your axes will be characterized by particularly smooth, good, and uniform running behavior.

Factsheet

- Lower drive power due to reduction in displacement force of more than 40%
- Improved control of the drive or linear axis
- Very smooth and uniform running behavior due to reduction in displacement force fluctuations of up to 30%
- Higher surface qualities in machining centers
- Suitable for use in measuring machines

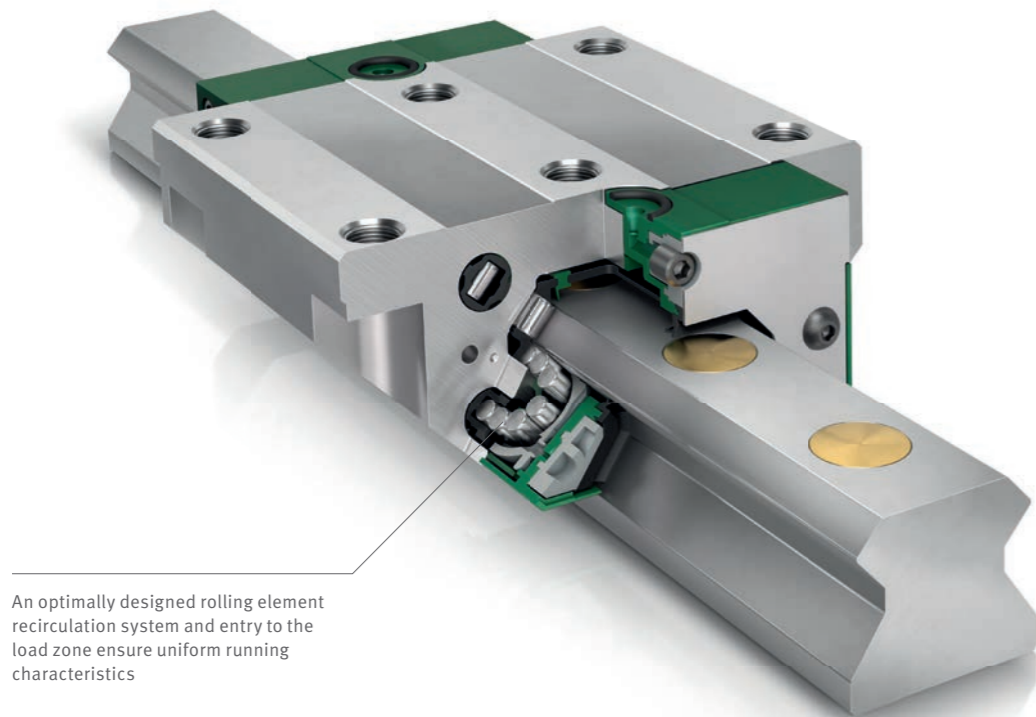

An optimally designed rolling element recirculation system and entry to the load zone ensure uniform running characteristics

SEALED – FOR THE OPERATING LIFE OF THE MACHINE

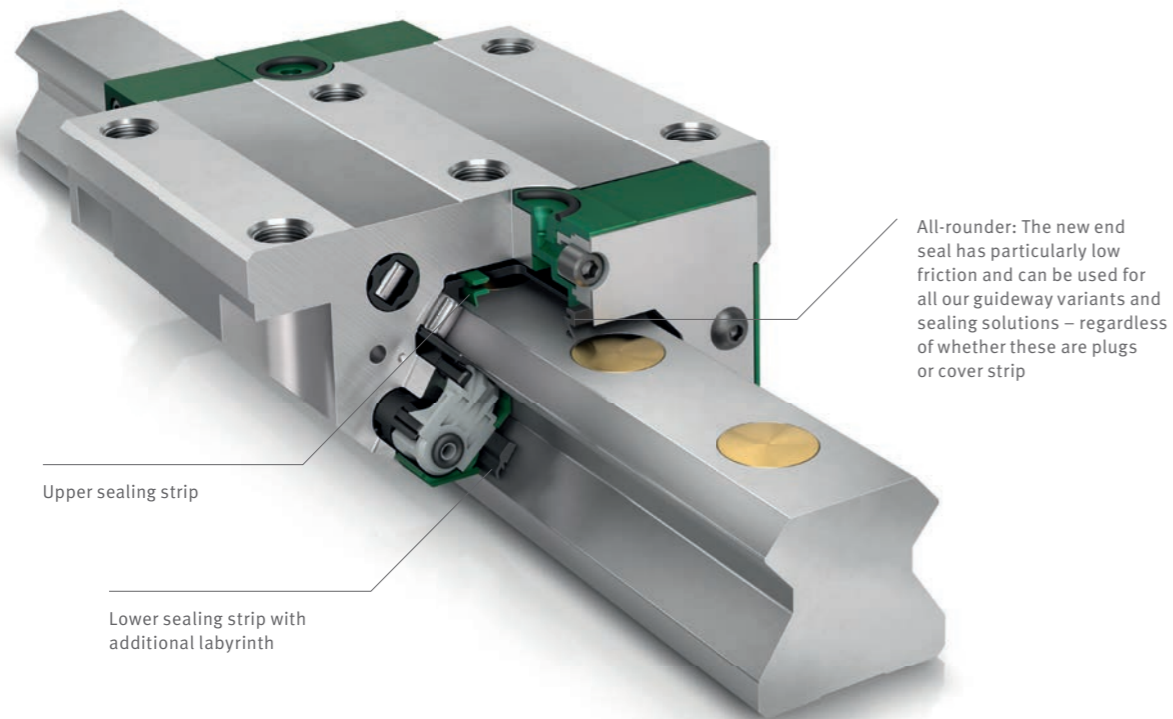

All-rounder: The new end seal has particularly low friction and can be used for all our guideway variants and sealing solutions – regardless of whether these are plugs or cover strip

Upper sealing strip

Lower sealing strip with additional labyrinth

Important for the operating life and operational reliability: A comprehensive sealing solution

Reliable seals are vitally important for the operating life of monorail guidance systems with rolling elements. Not only metal chips and cooling lubricants, but also particles of ceramic and glass and residues from additive manufacturing processes are found in today's machining compartments. We are taking account of the trend towards combining different production technologies in machining centers with our newly-designed seals.

At the same time, we were aiming to produce a standardized and reliable seal design for all our guideway variants. The majority of requirements in various applications are covered by the standard design. As is usually the case at Schaeffler, we also offer additional seals for various ambient conditions and manufacturing methods.

Factsheet

- Standardized seal lip geometry for use with both closing plugs and the new slide-in ADE cover strip
- Optimum wiping results while providing maximum protection against the ingress of contamination and the lowest displacement forces
- Optimized lower and upper sealing strips including additional labyrinth seal
- Further seal variants for various ambient conditions and manufacturing methods

FAST AND RELIABLE ASSEMBLY

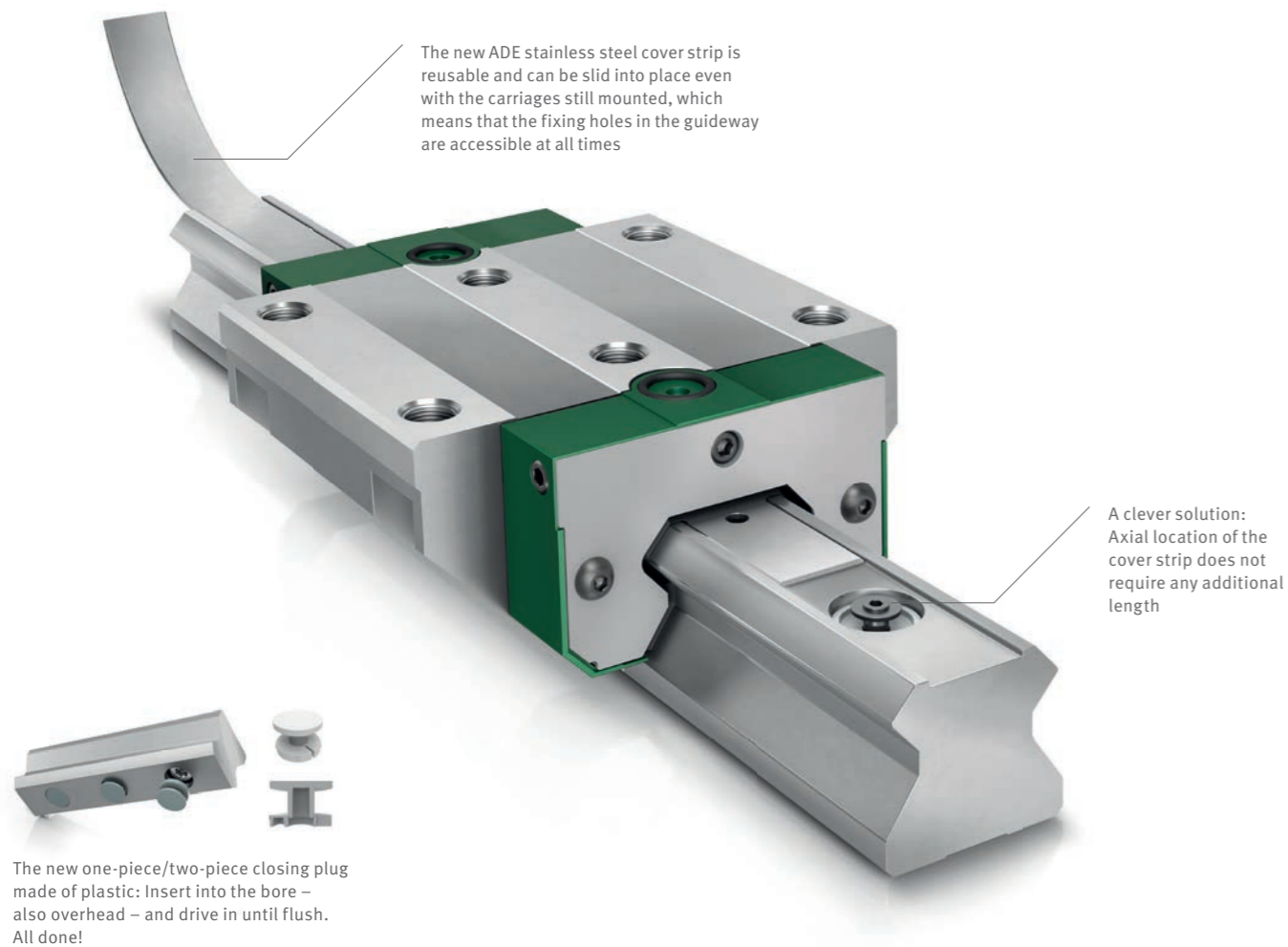
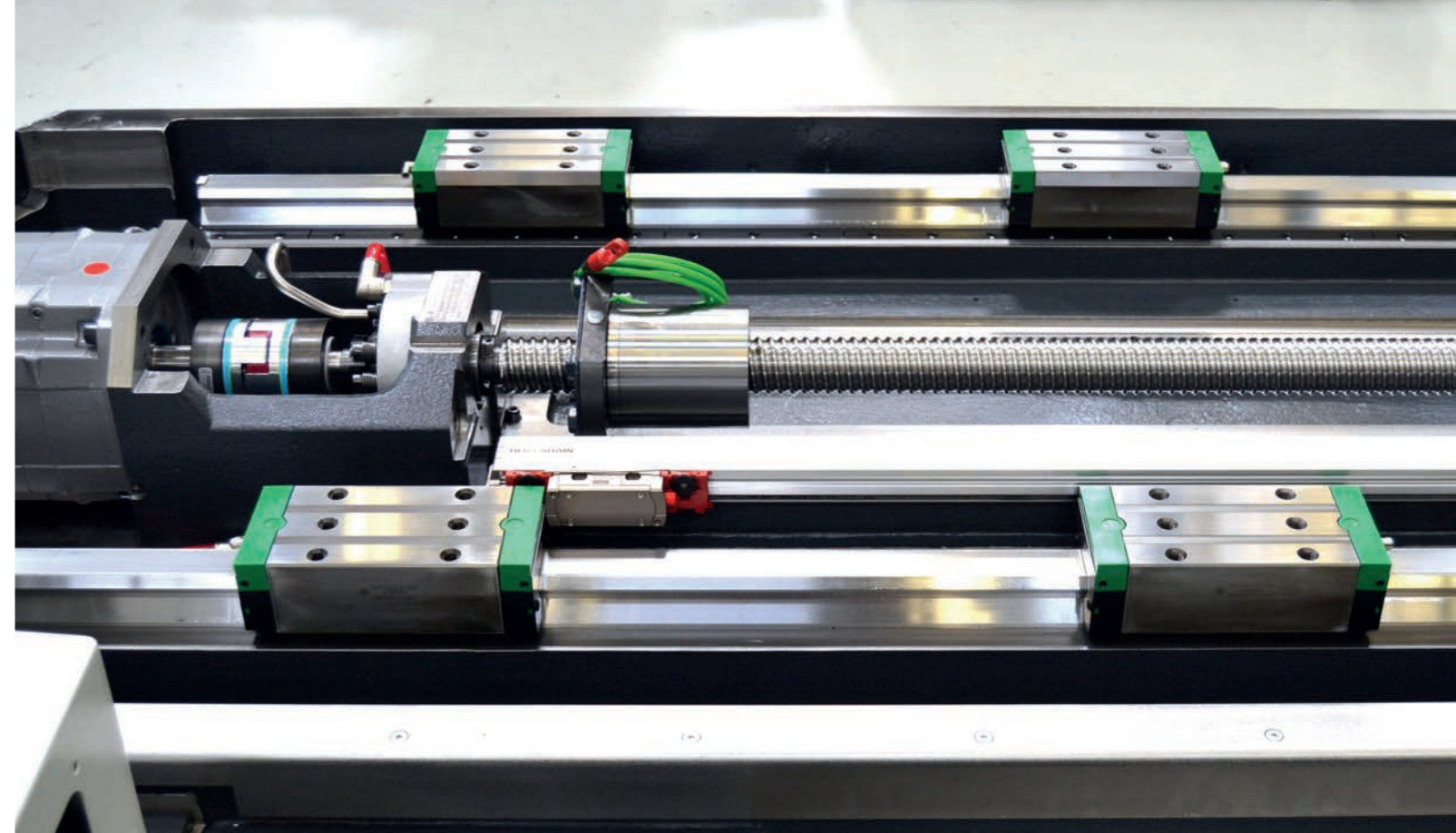

The new ADE stainless steel cover strip is reusable and can be slid into place even with the carriages still mounted, which means that the fixing holes in the guideway are accessible at all times

A clever solution: Axial location of the cover strip does not require any additional length

The new one-piece/two-piece closing plug made of plastic: Insert into the bore – also overhead – and drive in until flush. All done!

Cost-effectiveness begins with the mounting solution

As a machine and plant manufacturer, you are mainly interested in three things about linear axes: A short assembly time, a guarantee that no damage occurs to the seals in the carriages, and easy readjustment of the guideways when the machine table is mounted. For the time required to mount the linear axis, the sealing of the fixing holes in the guideways is a factor that cannot be disregarded. For this purpose, we have developed a new one-piece/two-piece closing plug made of plastic, which comprises a retaining ring and the actual plug. The one-piece design makes handling much easier. The new ADE

stainless steel cover strip can be mounted even faster. It is simply slid into the guideway – as often as required! To facilitate readjustment and fine adjustment of the linear axis, the cover strip can be simply slid until the relevant fixing screws are exposed, even with the carriages still mounted. The location of the cover strip is solved in such a way that the entire length of the guideway can be used. A self-retaining dummy guideway that is matched to the contour of the guideway makes it easier to slide the carriages onto the guideway.

Factsheet

- A self-retaining dummy guideway makes it easier to slide the carriage onto the support rail
- User-friendly due to increased mounting reliability
- The new closing plug reduces the mounting time by 50% compared to comparable solutions on the market
- Reusable stainless steel cover strip – can be mounted easily and very quickly even with the guide carriages still mounted

DIGITALIZED MONORAIL GUIDANCE SYSTEM

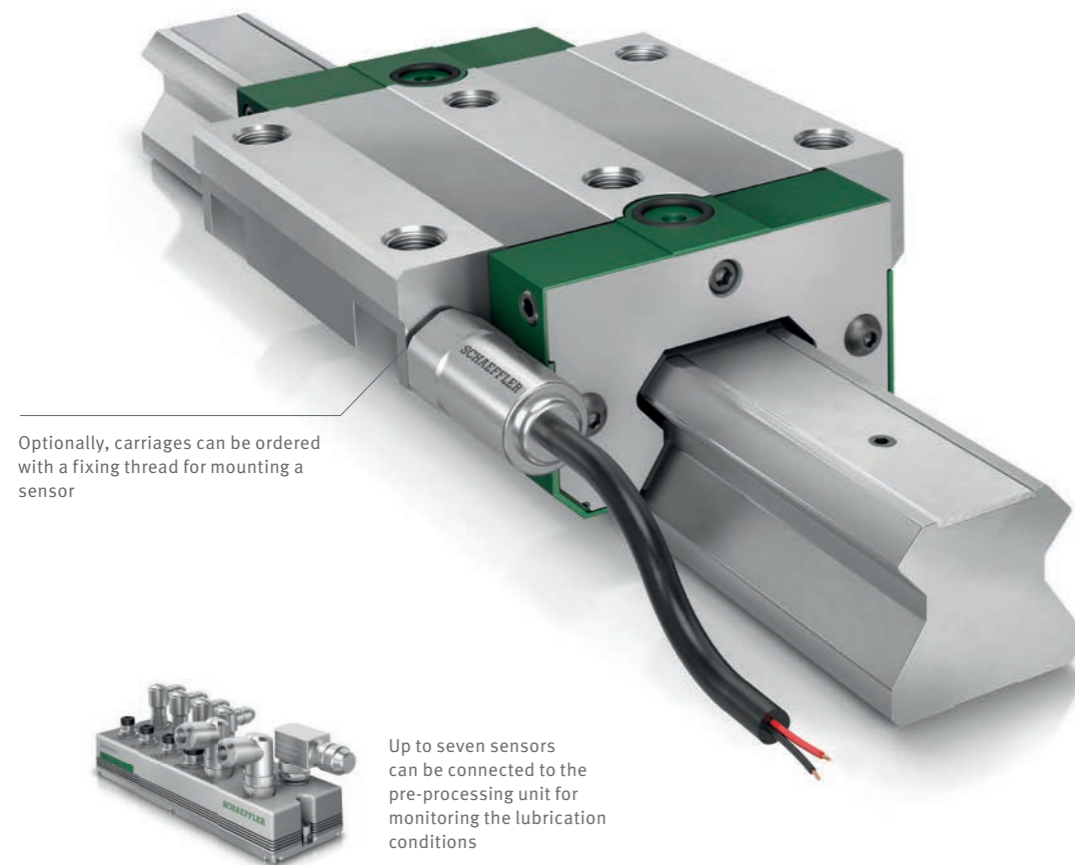

Optionally, carriages can be ordered with a fixing thread for mounting a sensor

Up to seven sensors can be connected to the pre-processing unit for monitoring the lubrication conditions

A monitoring solution with many possible applications

With Schaeffler DuraSense, we have developed the world's first monitoring solution for monorail guidance systems. The optional equipment that can be ordered offers several functions, e.g. monitoring the lubrication conditions of the carriages. If a limit value is exceeded, the system initiates a trigger signal for the relubrication cycle and therefore ensures requirement-based lubrication. In practice, this reduces the lubricant requirement by up to 30%. If a defect occurs in the lubrication system,

such as a lack of lubricant or a blocked or leaking supply line, DuraSense detects it and transmits a corresponding warning signal to the machine's control system.

The system also helps to detect damage in guidance systems at an early stage. This prevents unplanned downtimes and increases the availability of machines and equipment.

Factsheet

- Monitoring for linear axes with monorail guidance systems
- Reduces unplanned machine downtimes and increases the availability of machines and equipment
- Detection of defects in the lubrication system
- Optimum lubrication conditions in the linear guidance system
- A longer operating life of linear axes can be achieved
- Constantly high levels of manufacturing quality
- Lubricant requirement reduced by up to 30%

ADDITIONAL SOLUTIONS

Modifications or even surprises may occur during development or as late as the volume production phase. It is good to be able to draw on a modular range of accessories that can solve many problems. We focus on two main areas here: The optimization of the lubrication system and additional functions such as braking, clamping, and damping.

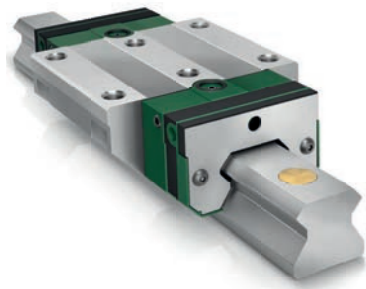

KIT – modular “long-term lubrication unit” concept

We offer high-volume, long-term lubrication units as a solution for low-maintenance or maintenance-free applications. They are supplied ready for immediate use and can of course be refilled with lubricant. It is of course also possible to retrofit the long-term lubrication units.

Benefits

- Lubricant reservoir with a large storage capacity
- A lubricant supply in any mounting position
- Minimized egress of lubricant from the guidance system due to a double lip end wiper
- Lower operating and maintenance costs due to extended maintenance intervals
- Completely maintenance-free depending on the environmental and operating conditions

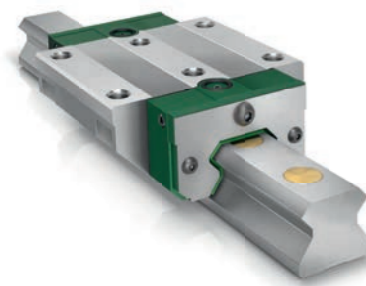

KIT – modular “seal” concept

The combination of sealing elements that are matched to each other is based on practical experience. Single lip or double lip end seals and sealing strips made from proven seal materials are optionally available.

Benefits

- Variable use of different sealing elements, also in a cascade
- Customized combinations upon request
- Reduced assembly outlay, problem-free retrofitting, and fast replacement
- Simpler, predictive stockholding
- Positioning can be freely selected

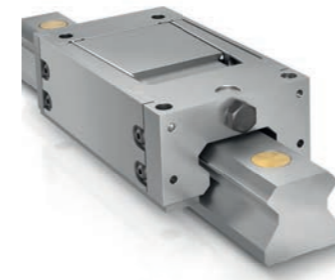

BKE.TSX braking and clamping element

This important safety element brakes the linear axis safely in the event of a power drop or control system failure. The driven axes, which do not have their own braking and clamping function, are stopped reliably and at lightning speed without external energy – for the protection of man and machine.

Benefits

- Can also be used as an emergency stop brake
- Reaction time under 40 milliseconds
- Safe, powerful braking of linear axes
- Cost-effective, maintenance-free system
- Compact solution in the same design envelope as the linear recirculating roller bearing and guideway assembly
- Brake shoes that fit closely without clearance with self-adjusting wear compensation



RUKS clamping element

This hydraulic clamping element is primarily used for locking machining axes. It is also possible to minimize the axial clearance in the traverse direction. RUE-F linear recirculating roller bearing and guideway assemblies can be retrofitted with RUKS clamping elements at any time.

Benefits

- High clamping force and simple assembly in the same design envelope as a linear recirculating roller bearing and guideway assembly
- The optimized cutting and machining accuracy of high-performance machines
- Prevents micromovements under oscillating loads
- Improves the axial rigidity of the clamped axis



RUDS damping carriage

This damping carriage prevents vibrations acting on the guidance system in an effective manner. It slides on a film of oil between the damping carriage and the guideway. The ready-to-fit carriage is simply screw mounted to the adjacent construction during assembly; positioning in front of or behind the linear recirculating roller bearing and guideway assembly depending on the vibration type.

Benefits

- Effective damping of linear axes due to squeeze film effect
- Pulse lubrication or non-pressurized oil feed
- Additional crash protection for the linear guidance system
- Increased surface quality of the workpiece due to “chatter-free” machining, even in the maximum load range

Schaeffler Technologies AG & Co. KG

Berliner Straße 134
66424 Homburg
Germany
www.schaeffler.de
info@schaeffler.com

Every care has been taken to ensure the correctness of the information contained in this publication but no liability can be accepted for any errors or omissions. We reserve the right to make technical changes.

© Schaeffler 2021

Issued: 2021, May

This publication or parts thereof may not be reproduced without our permission.