

EWELLIX

# EWELLIX High-performance Actuator e-MOVEKIT

Product Data Sheet

We pioneer motion

**SCHAEFFLER**



# 1 System description

The e-MOVEKIT is a complete system offer that consists of all components required to drive a linear actuator in mobile machines that use 24V batteries. It was tested according to industry standards.

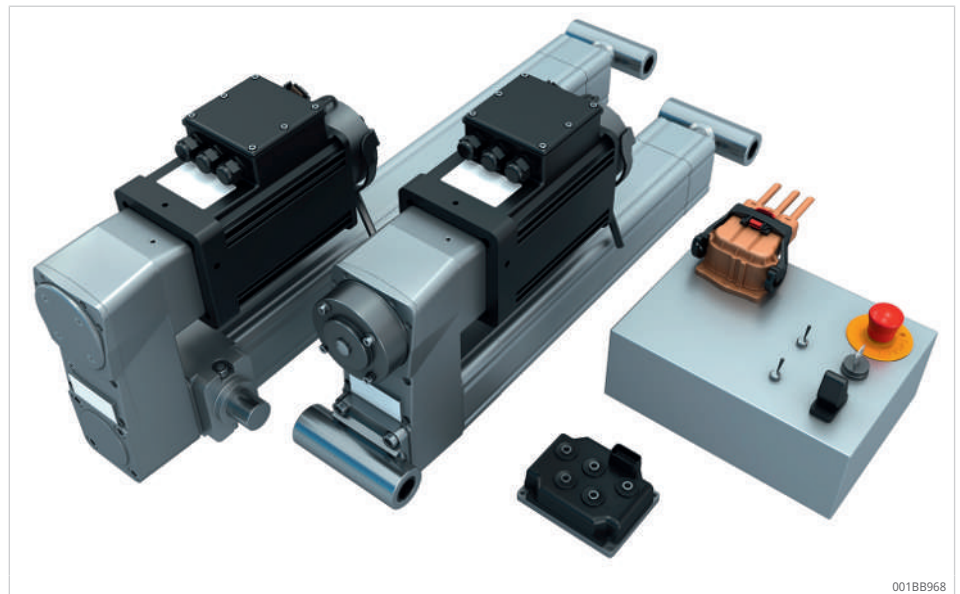

The system allows for linear movements controlled by analog inputs or through CAN commands. It also offers features that make it easy to replace hydraulic systems like:

- Easily integrate the actuator into an existing system
- Start using electromechanics with little knowledge required (system integration e-MOVEKIT, quick start e-MOVEKIT)
- Build prototypes quickly / perform feasibility studies
- Purchase all components from a single supplier
- Get support from one supplier (one stop shop)
- Reduce amount of technical interfaces
- Reduce complexity of the system
- Recuperate energy: battery can be charged by recuperating energy when the system is driven (and not actively driving) e.g., when moving down in a lifting device. This increases overall efficiency and can increase the availability. Alternatively, the customer can reduce the battery size compared to a standard hydraulic system
- Operate the actuator in industries that are sensitive to contamination e.g., food industry, server farms or clean rooms
- Oil free
- Reduced maintenance interval and efforts
- Fully documented performance and environmental testing for mobile requirements

## 1.1 Control system

To make integration into any system as simple and smooth as possible, Schaeffler provides several motor control options. With these controllers we can offer the optimal performance in any application.

Both kits can be combined with any of the listed actuator configurations. Schaeffler configures all motor parameters according to the selected actuator. Both kits are equipped with Curtis instruments' AC F2-A motor controller.

### Quick start e-MOVEKIT

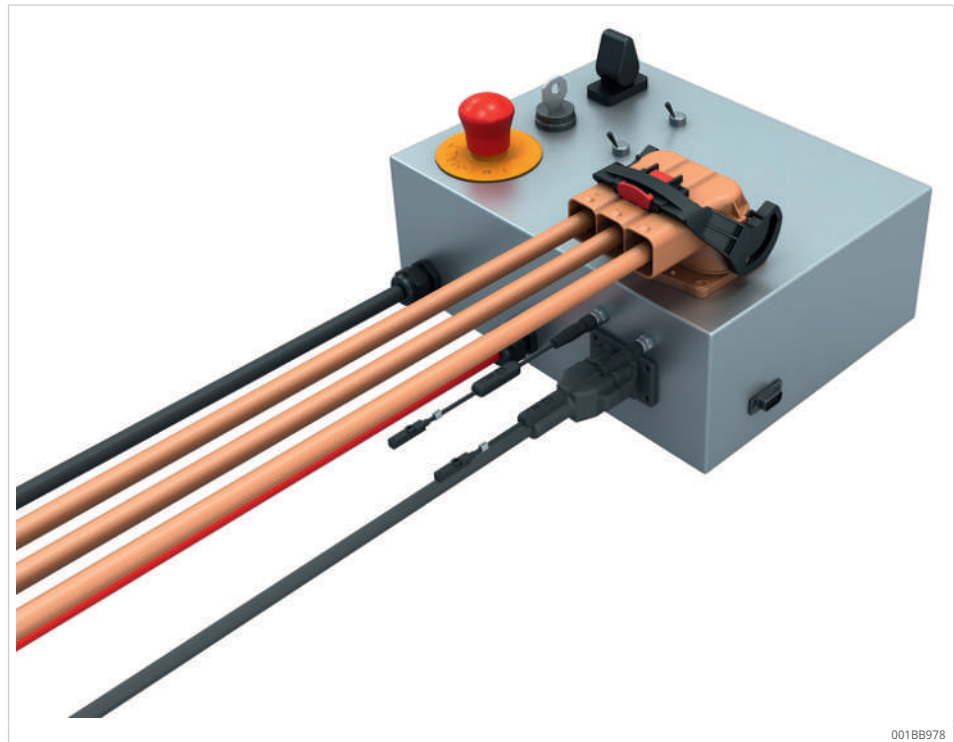

The quick start e-MOVEKIT is designed for customers unfamiliar with electro-mechanical actuators. It comes with all the components needed to start testing straight out of the box, including the motor controller with all the input controls and cables needed to drive the actuator within the application. The quick start e-MOVEKIT is ideal for prototyping and concept studies.

## System integration e-MOVEKIT



The system integration e-MOVEKIT requires a basic knowledge of motor control techniques. The system is already configured with the motor parameters for motor kit N11. While the integration into the application is defined by the customer.

With the system integration e-MOVEKIT, Schaeffler offers a solution for complete one-handed actuator control.

### 1.2 Speed mode

By giving a drive command, the controller will drive the motor at the required speed and adjust the power consumption and torque generation accordingly.

For smooth starts and stops an acceleration ramp can be defined to reduce strain on mechanical components and allow for longer life and a high end feel.

#### Software features:

- CANopen drive commands
- Analog drive commands (FWD/REV or WIG/WAG)
- Limit switch integration possible, standard for the quick start e-MOVEKIT
- Validated safety detection and error prevention:
  - Un-commanded powered motion
  - Motor braking torque loss

### 1.3 Actuator select

To facilitate customers in defining their own actuator, Schaeffler has released an online configurator, where you can configure your optimal EMA-100 cylinder in just a few steps. Since the cylinders are assembled with standard components, any customer defined configuration will not influence the lead time.

To meet any space and performance requirements, Schaeffler provides inline and parallel gearboxes as well as AC and servo motors. All motors are equipped with specific adapters to keep the same mechanical interface, independent of the selected motor type.

This standardized interface allows customers to also attach their own preferred motor, that customers are already familiar with (motor and drives).



medias | Engineering Tool |  
Actuator select |  
<https://www.schaeffler.de/std/204A>

## 2 Quick start e-MOVEKIT

The quick start e-MOVEKIT is specially designed to allow easy first prototype integration and build-up of control know-how for electromechanic actuators. The box already contains all necessary components to get started and is truly a plug-and-play solution. The intend of the quick start e-MOVEKIT is to help in the transition from an existing hydraulic system to an all-electric one. The simple and easy to understand control interface allows for fast prototype testing inside the application.

To prevent any damage to the actuator during the first setup and building the know-how about controlling electromechanics actuators inside the application the actuators ordered together with the quick start e-MOVEKIT comes equipped with limit switches that prevent an overtravel into the physical end stops of the actuator.

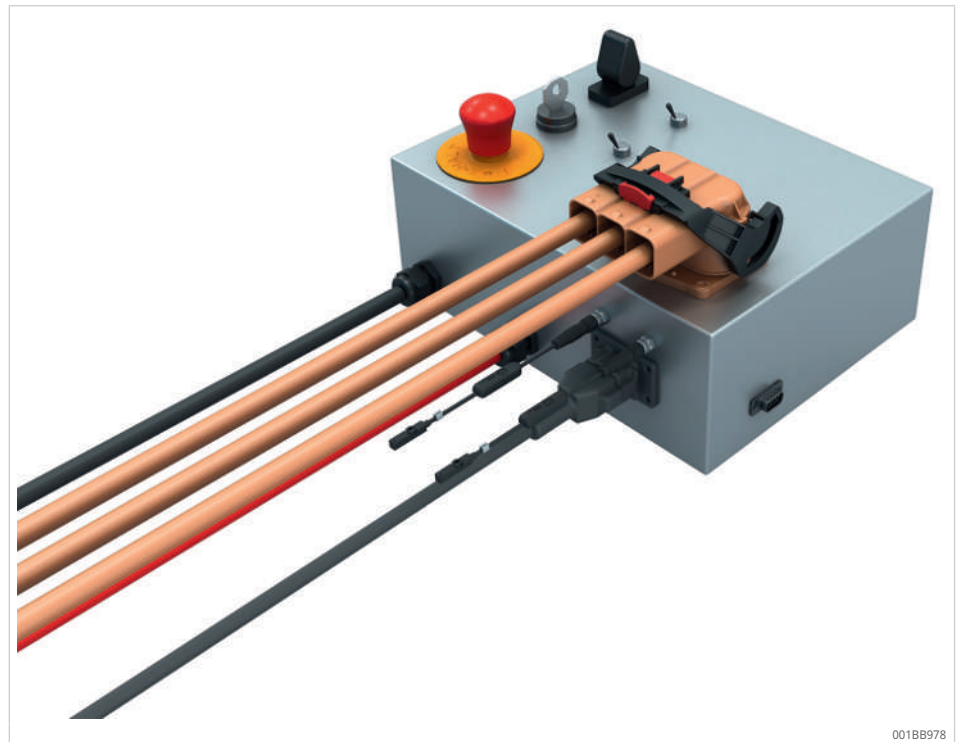

### Quick start e-MOVEKIT contains:

- Control box
- Motor power cable
- Motor control cable
- Limit switch sensor
- Limit switch extension cable

### To be ordered separately:

- Linear unit
- Nidec N11 motor
- Attachments & accessories
- Battery 24 V DC (not available from Schaeffler)

## 2.1 Performance data

Designation	Symbol	Unit	Data
Controller type	-	-	AC-F2-A-200-001
Interlock	-	-	Integrated
Nominal voltage range	-	-	24
Minimum voltage	$U_{\min}$	V DC	12
Burnout voltage	$U_{\text{burn}}$	V DC	8
Maximum voltage	$U_{\max}$	V DC	30
Maximum current [S2-2 min]	$I_{\max}$	A RMS	200
Maximum current [S2-60 min]	$I_{\max}$	A RMS	67
Designed life	-	-	8 000
Current protection (Fuse)	-	-	250
Environmental rating	IP	-	65/67

## 2.2 Dimensions

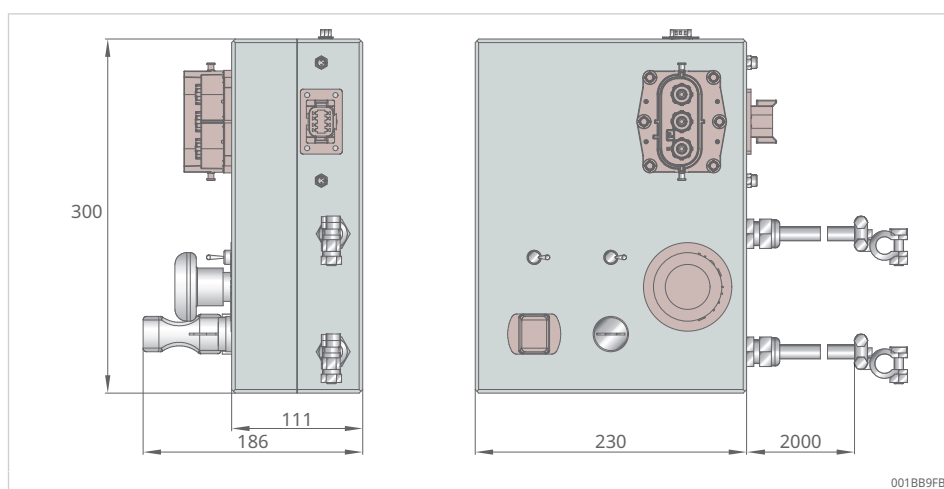

### Motor power cable for quick start e-MOVEKIT



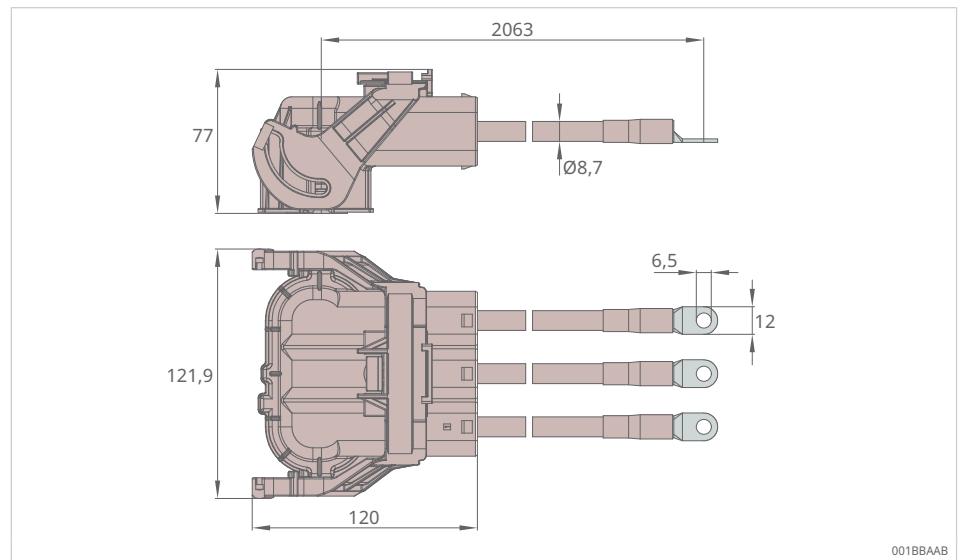

Type: ZKA-377946

Connector: Ampenol 3 PIN plug right angle HVSL1000 08 3 A 1 25

Motor control cable for quick start e-MOVEKIT

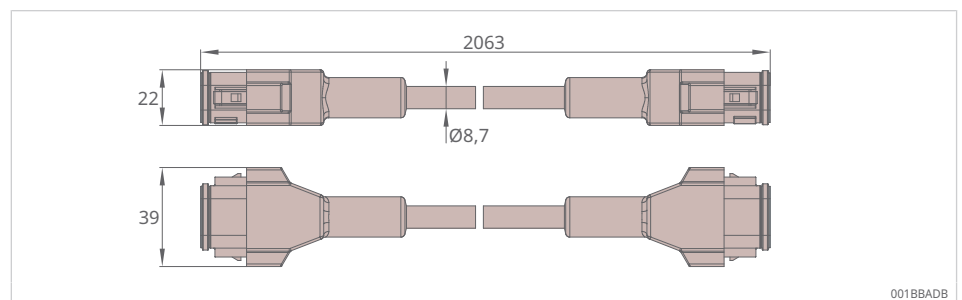

Type: ZKA-377945

Connector: Deutsch DT06-08SA

Proximity switch for quick start e-MOVEKIT

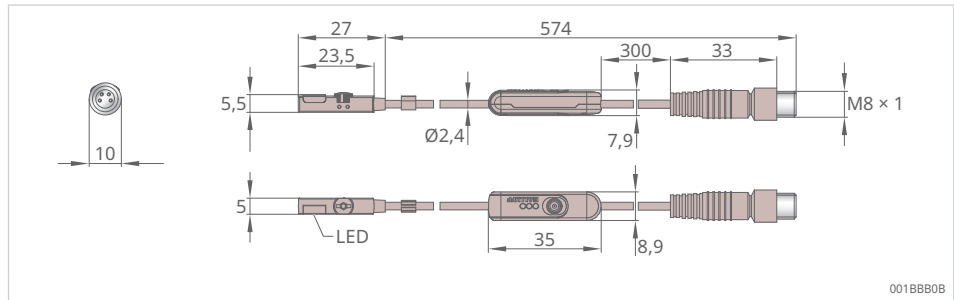

Type: ZSC-377942

Extension cable for proximity switch

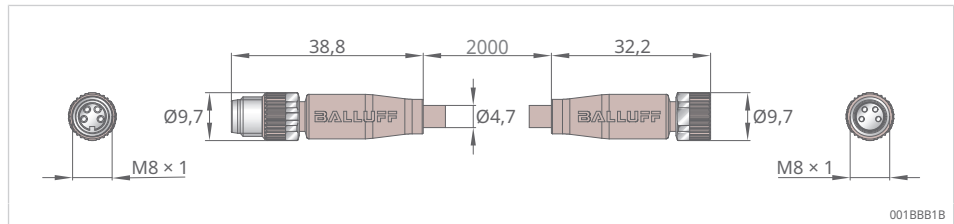

Type: ZSC-377943

### 3 System integration e-MOVEKIT

The system integration e-MOVEKIT allows for an integration into any mobile application. The controller comes pre-configured to run with the AC induction motor and allows for a direct integration and gives high flexibility for the integration into any application.

The system integration e-MOVEKIT is targeted for customers that want to realize a product in small series and like to have one single source for all components necessary to control an electromechanical actuator.

3



001BB988

#### System integration e-MOVEKIT contains:

- Motor controller
- Motor profile pre-setup cable

#### To be ordered separately:

- Linear unit
- Nidec N11 motor
- Motor power cable
- Motor control cable
- Attachments & accessories
- Battery 24 V DC (not available from Schaeffler)

### 3.1 Performance data

Designation	Symbol	Unit	Data
Controller type	-	-	Curtis AC F2-A 24-200-01
Nominal voltage range	-	-	24
Minimum voltage	$U_{\min}$	V DC	12
Burnout voltage	$U_{\text{burn}}$	V DC	8
Maximum voltage	$U_{\max}$	V DC	30
Maximum current [S2-2 min]	$I_{\max}$	A RMS	200
Maximum current [S2-60 min]	$I_{\max}$	A RMS	67
Storage ambient temperature	$T_{\text{amb\_stor}}$	°C	-40 to +95
Operation ambient temperature	$T_{\text{amb\_op}}$		-40 to +50
Designed life	-	-	8 000
Environmental rating	IP	-	65/67

### 3.2 Dimensions

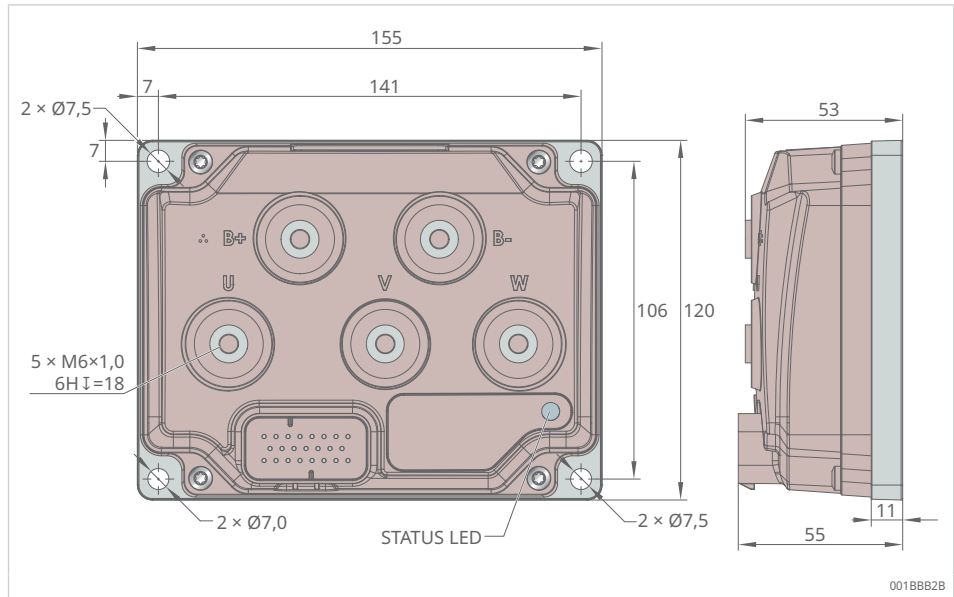

### Motor power cable for system integration e-MOVEKIT

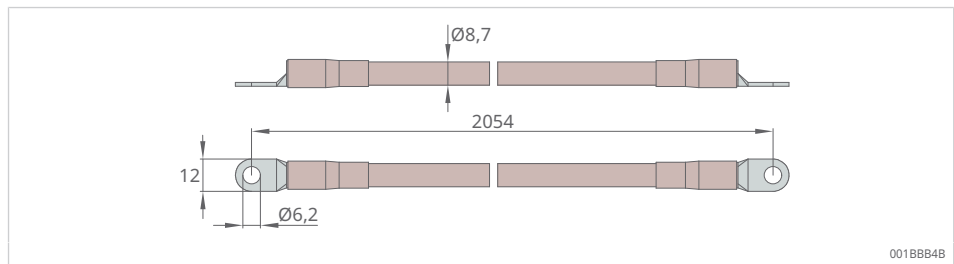

Type: ZKA-377947

### 23pin AMPSEAL - Pre-assembled connector for I/O to the motor controller

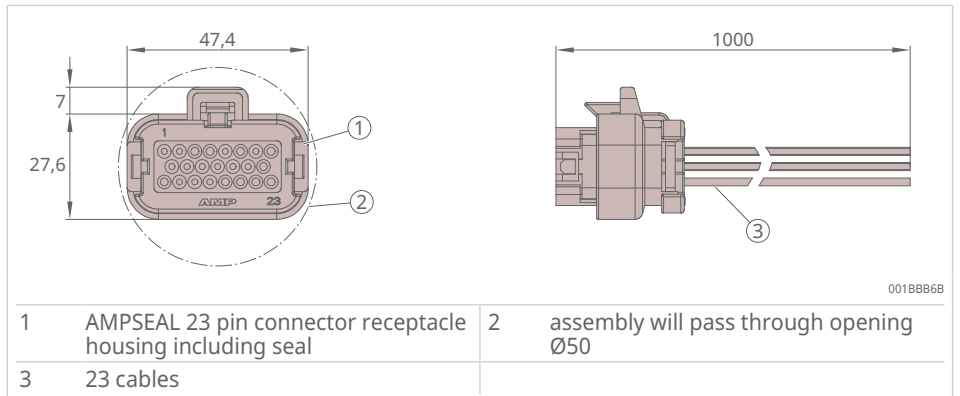
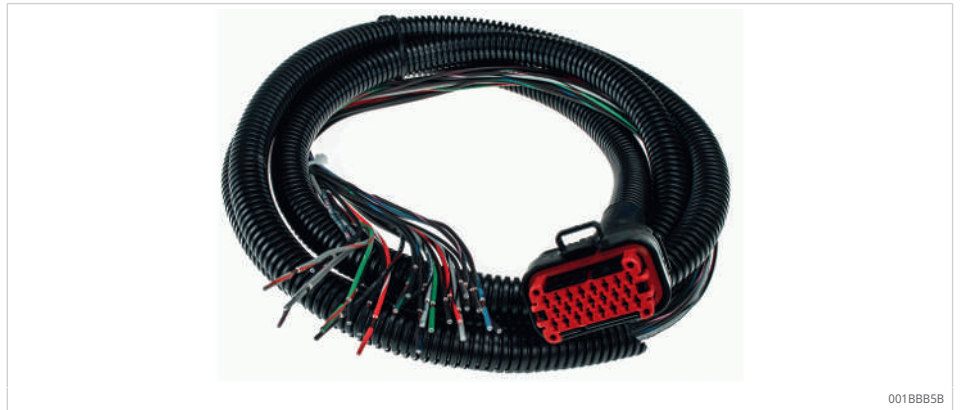

Type: ZKA-377944

## 4 AC induction motor, e-MOVEKIT

1 AC induction motor, e-MOVEKIT

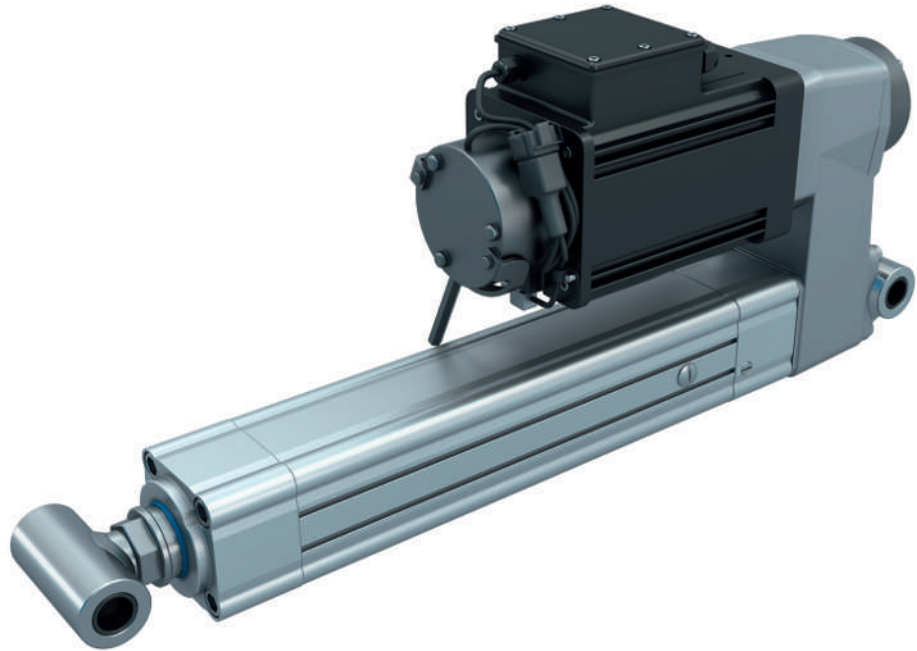

001B88B6

With this AC induction motor most hydraulic application use cases for mobile machinery can be fulfilled. This motor together with the quick start e-MOVEKIT or the system integration e-MOVEKIT allows for a plug-and-play solution for a wide variety of applications running on 24 VDC battery power. This motor provides high power in a small footprint and was specially designed for the application in linear actuators. The included fail-safe electromagnetic brake allows for a safe operation state in every situation.

### Technical data

Designation	Sym- bol	Unit	Data
Motor Type	-	-	Nidec AC induction motor, 1,4kW, with EM-brake
Ordering key	-	-	B0-N11
Rated output power	P <sub>M</sub>	kW	1,4
Bus voltage	U	V DC	24
Rated voltage	U <sub>rated</sub>	V AC	16
Rated current	I <sub>rated</sub>	A	85
Rated speed	n <sub>rated</sub>	rpm	2050
Maximum speed	n <sub>max</sub>	rpm	3000
Rated torque (S3-15%)	M <sub>rated</sub>	Nm	6,05
Peak torque (S2-2 min)	M <sub>peak</sub>	Nm	25
Speed sensor	-	-	2 × 64 pulse quadrature encoder
Temperatur sensor	-	-	PT1000
Brake type	-	-	Electromagnetic
Brake voltage level	U <sub>brake</sub>	V DC	24
Brake power level	P <sub>brake</sub>	W	25
Manual brake release	-	-	lever

## 4.1 Performance diagram

### Speed-load diagrams (S2-2 min)

2 Speed-load diagrams (S2-2 min)

EMA-100-1-BB/CB

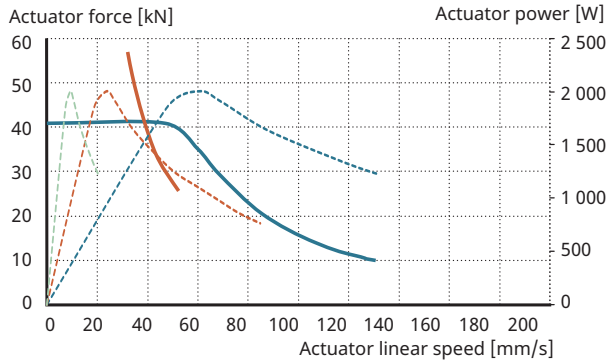

EMA-100-1-BC

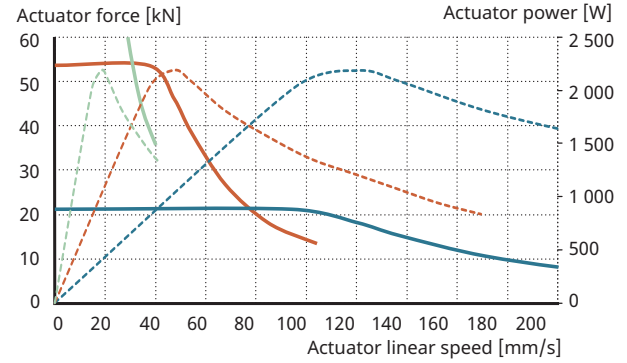

Actuator force — Gearing ratio 4:1 — Gearing ratio 10:1 — Gearing ratio 25:1  
 Actuator power — Gearing ratio 4:1 — Gearing ratio 10:1 — Gearing ratio 25:1

001DE9AD

### Safety factor load diagrams

3 Safety factor load diagrams

EMA-100-1-BB/CB

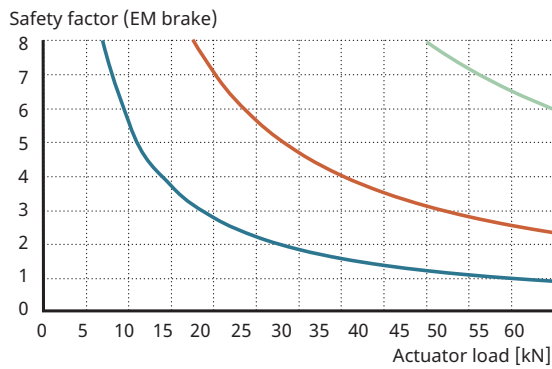

EMA-100-1-BC

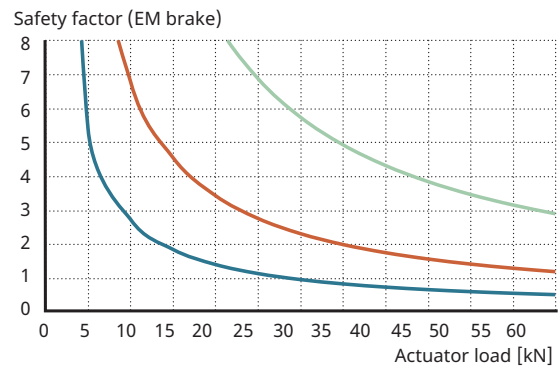

— Gearing ratio 4:1 — Gearing ratio 10:1 — Gearing ratio 25:1

001DE9BD

## 4.2 Dimensional drawing

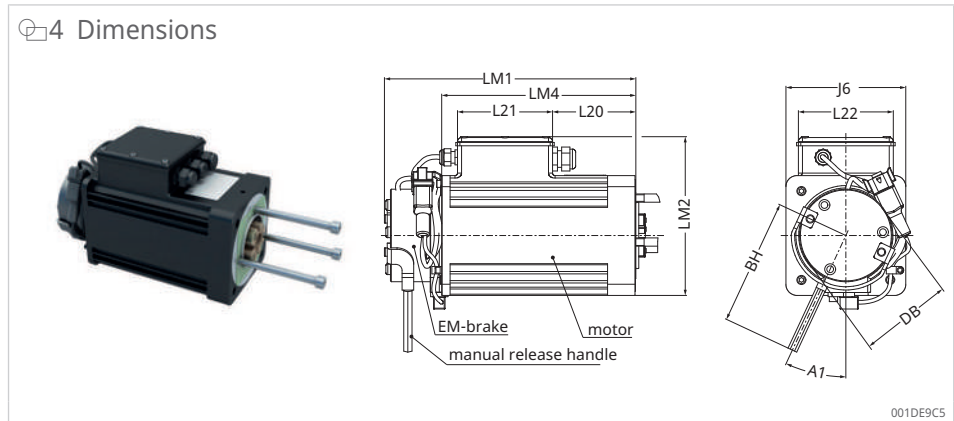

### 1 Dimensions

Type	LM1	LM2	LM4	L20	L21	L22	J6	A1	BH	DB
-	mm									
MK-100-MA-B0-N11	304,2	192	234,8	100,8	115	115	145	25°	153	Ø 112

## 5 Compliances system integration e-MOVEKIT

### 2 Compliances system integration e-MOVEKIT

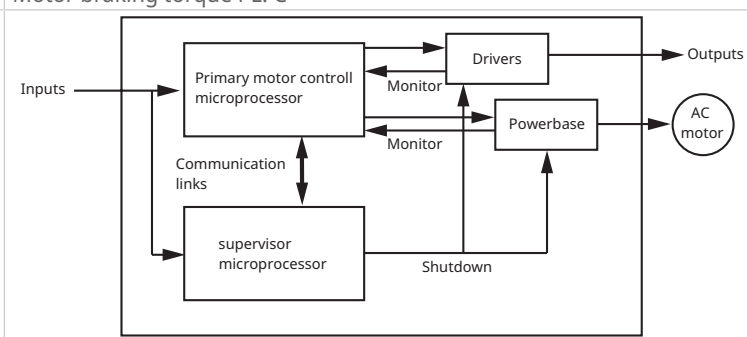
Test	Standard
EMC	Designed to the requirements of EN 12895:2015
Safety	Designed to the requirements of EN 1175-1:1998+A1:2010, EN ISO 13849-1:2015 Category 2 Uncommanded powerd motion PL: d Motor braking torque PL: C
Supervision system	 <p>The diagram illustrates the supervision system architecture. It features a Primary motor control microprocessor and a supervisor microprocessor connected via communication links. The Primary motor control microprocessor is linked to Drivers and a Powerbase, with 'Monitor' signals flowing from the microprocessors to these components. The Drivers and Powerbase are connected to an AC motor. A 'Shutdown' signal is shown originating from the supervisor microprocessor and directed towards the Powerbase. The entire system is fed by 'Inputs' and produces 'Outputs'.</p>
UL	UL recognized component per UL 583
Ingress protection	IP65 per IEC60529
Temperature	Controller linearly reduces maximum current limit with an internal heatsink Temperature from 85 °C to 95 °C; complete cutoff occurs above 95 °C and bellow -40 °C.
Others	RoHS directive 2011/95/EU compliant REACH regulation (EC) 1907/2006 compliant Dodd Frank Act compliant

## 6 Ordering key

### e-MOVEKIT

#### 5 Structure of the ordering designation e-MOVEKIT

C A M - C Q - N C B A - X X X - 0 - 0 0 0

#### Type

- Q Quick start e-MOVEKIT (including cables, sensors)
  - S System integration e-MOVEKIT (without cables)
- Cables for system integration e-MOVEKIT are sold as ZKA items

#### Motor type

- N Nidec AC induction motor, 1.4 kW, with electromagnetic brake

#### Gearbox size

- C Small parallel gearbox

#### Gear ratio

- B 4:1 (spur only, see chapter "Parallel gearboxes" for exact ratio)
- C 10:1 (spur only, see chapter "Parallel gearboxes" for exact ratio)
- D 25:1 (spur only, see chapter "Parallel gearboxes" for exact ratio)

#### Spindle type

- A Ball screw drive 32×10
- B Ball screw drive 40×10
- C Ball screw drive 40×20

#### Speed

Linear speed of the unit in mm/s

The speed for options with end switches is limited to 90 mm/s ,  
increments of 10 mm/s available as standard, other maximum speeds available by agreement

#### Other options - sensor

- 0 No sensor integration
- 1 Integrated magnetic end switches  
(automatically selected with quick start e-MOVEKIT)

#### Customer-specific options

- 000 No customer-specific option

001C99CD



**Schaeffler Technologies AG & Co. KG**

Georg-Schäfer-Straße 30

97421 Schweinfurt

Germany

[www.schaeffler.de/en](http://www.schaeffler.de/en)

[info.de@schaeffler.com](mailto:info.de@schaeffler.com)

In Germany:

Phone 0180 5003872

From other countries:

Phone +49 9721 91-0

All information has been carefully compiled and checked by us, but we cannot guarantee complete accuracy. We reserve the right to make corrections. Therefore, please always check whether more up-to-date or amended information is available. This publication supersedes all deviating information from older publications. Printing, including excerpts, is only permitted with our approval.  
© Schaeffler Technologies AG & Co. KG  
PDB 115 / 01 / en-US / 2026-04