



EWELLIX

EWELLIX Lifting Columns

TXG

User Manual

We pioneer motion

SCHAEFFLER

Contents

1	About the manual.....	6
1.1	Information in this user manual.....	6
1.2	Symbols	6
1.3	Signs.....	6
1.4	Availability	7
1.5	Legal notices	7
1.6	Limitation of liability.....	7
1.7	Warranty terms.....	7
1.8	Customer service.....	8
1.9	Images	8
2	General safety regulations	9
2.1	Intended use	9
2.1.1	Product service life.....	9
2.2	Unintended use	9
2.3	Responsibility of the owner and processor.....	10
2.4	Personnel requirements.....	10
2.4.1	Qualifications	11
2.5	Protective equipment	11
2.6	Hazards.....	11
2.7	Safety regulations.....	12
2.7.1	Safety equipment	12
2.7.2	Safeguarding against restart.....	13
2.7.3	Modifications to the device	14
2.7.4	Spare parts.....	14
2.7.5	Work on electrical devices.....	14
2.7.6	Transport and storage.....	14
2.7.7	Operation	15
3	Scope of delivery.....	16
3.1	Check for damage during transit	16
3.2	Check for defects	16
4	Product description	17
4.1	Control unit: Stand-alone and master	18
4.1.1	Requirements for third-party control units	18
4.2	Terminal-position shutdown	19
4.3	Connections	19
4.4	Operating element	19
4.5	Options	20
4.6	Required accessories	20

5	Transport and storage	21
5.1	Transport	21
5.2	Storage.....	21
5.3	Return to the manufacturer	21
6	Mounting	22
6.1	Installing the lifting column	23
6.2	TXG10: Connecting to the control unit	25
6.3	Connecting the operating element.....	26
6.3.1	Connecting the operating element for lifting column TXG10	26
6.3.2	Connecting the operating element to the lifting column (all types except TXG10).....	26
6.4	Connecting the mains cable.....	27
6.4.1	TXG10 (stand-alone): Connecting the control unit to the power supply	27
6.4.2	Connecting the lifting column (all types except TXG10) to the power supply.....	27
6.5	Connecting the 2nd lifting column for master-slave operation (optional)	28
6.6	Establishing strain relief	29
7	Commissioning	30
7.1	Inspections prior to initial commissioning.....	30
7.2	Performing the initialisation run for parallel operation	30
7.3	Performing the initialisation run for the memory function	30
8	Operation	32
8.1	Implementing protective measures.....	32
8.2	Switching on.....	32
8.3	Switching off	33
8.4	Actions during operation.....	33
8.4.1	Actuating a single lifting column (stand-alone operation)	33
8.4.2	Actuating lifting columns in parallel operation (parallel operation option)	34
8.4.3	Using the memory function	35
8.4.4	Working in master-slave operation	36
8.5	Emergency disengagement	36
8.5.1	Disconnecting the TXG10 lifting column (stand-alone or slave) from the control unit....	37
8.5.2	Disconnecting the lifting column from the power source (all types except TXG10).....	37
9	Troubleshooting	38
9.1	Lifting columns with mains connection (master or stand-alone).....	39
9.2	Lifting columns TXG10 (slave or stand-alone)	40
9.3	Startup after correcting a malfunction	40
10	Maintenance	41
10.1	Maintenance plan.....	41
10.2	Maintenance work.....	42
10.2.1	Cleaning.....	42
10.2.2	Inspections and readings.....	42
10.2.3	Service log	42
10.2.4	Visual inspection of the external condition	43
10.3	Measures following completed maintenance	44
11	Dismounting.....	45

12 Disposal	46
13 Technical data	47
13.1 Ambient conditions	48
13.2 Type plate	49
13.3 Plans and diagrams.....	49
13.4 Declaration of incorporation.....	51
14 Replacement parts and accessories.....	52
14.1 Replacement parts	52
14.2 Accessories.....	52

1 About the manual

This manual is part of the product and contains important information. Read the manual thoroughly prior to use and ensure that the instructions are strictly observed.

The original language of the manual is German. All other languages are translations from the original language.

1.1 Information in this user manual

This manual provides important information on how to work with the device safely and efficiently.

The manual is part of the device, must always be kept in the device's direct proximity and should be available for personnel to read at any time. All personnel working with the device must read and understand this manual before starting any work. Strict compliance with all specified safety notes and instructions is a basic requirement for safety at work.

Moreover, the accident prevention guidelines and general safety regulations applicable at the place of use of the device must also be complied with.

All information and instructions in this manual have been compiled in accordance with applicable standards and regulations, the present status of technology, and our many years of knowledge and experience.





1.2 Symbols

Safety precautions are identified by symbols and signal words as shown. The signal words indicate the severity of the hazard and the chance it could occur. Follow these safety precautions and act cautiously in order to avoid accidents, personal injury and damage to property.

The warning and hazard symbols are defined in accordance with ANSI Z535.6-2011.

1 Warning and hazard symbols

Signs and descriptions

 DANGER	In case of non-compliance, death or serious injury will occur.
 WARNING	In case of non-compliance, death or serious injury may occur.
 CAUTION	In case of non-compliance, minor or moderate injury may occur.
 NOTICE	In case of non-compliance, damage or malfunctions in the product or the adjacent construction may occur.

1.3 Signs

The warning, prohibition, and mandatory signs are defined in accordance with DIN EN ISO 7010 or DIN 4844-2.

2 Warning, prohibition, and mandatory signs

Signs and descriptions

	General warning
	Electrical voltage warning
	Observe the manual
	Wear safety shoes
	General mandatory sign

1.4 Availability



A current version of this manual is available at:
<https://www.schaeffler.de/std/223C>

Ensure that this manual is always complete and legible and is available to all persons engaged in transporting, fitting, dismantling, commissioning, operating, or maintaining the product.

Keep the manual in a safe place for immediate reference.

1.5 Legal notices

The information in this manual reflects the status at the time of publication.

Unauthorized modifications to or improper use of the product are not permitted. Schaeffler accepts no liability in these cases.

1.6 Limitation of liability

All information and notes in this manual were compiled with due consideration given to applicable standards and regulations, the present state of technology and our years of knowledge and experience.

The manufacturer is not liable for any damage resulting from:

- disregarding this manual
- unintended use
- employment of untrained personnel
- unauthorized conversions
- technical changes
- manipulation or removal of the screws on the drive
- use of unapproved spare parts.

Where the device has been customized, the actual product delivered may be different from what is described in this manual. In this case, ask Schaeffler for any additional instructions or safety precautions relevant to these devices.

We reserve the right to make technical modifications to the device to improve usability.

1.7 Warranty terms

The manufacturer's warranty terms apply.

1.8 Customer service

Schaeffler Customer Service is available at any time to assist with technical information and inquiries. The responsible contact person can be reached by telephone, e-mail, or via the Internet, see manufacturer's address on the back cover. Our employees are also always interested in receiving new information and practical experience. This information and experience helps us improve our products.

1.9 Images

The images in this manual may be schematic representations and may differ from the delivered device.

2 General safety regulations

This section provides an overview of all essential safety aspects for optimum personal protection as well as safe and trouble-free operation. Failure to observe this manual and the safety instructions contained herein may result in significant hazards and potentially lead to serious injury or death.

2.1 Intended use

The lifting columns have been designed and manufactured exclusively for the intended use described in this user manual. If the lifting column is used for any purpose other than that specified, the manufacturer cannot be held liable for any resulting damage.

Intended use of EWELLIX TXG lifting columns:

- moving or holding a load within the permitted operating limits
- dynamic stroke under centric or off-centric compressive load
- Designed for height adjustment in medical applications, computer workstations, and assembly tables. Any other use of the columns must be approved by the manufacturer.
- use in indoor environments

Observe the permissible operating data, operating limits, and ambient conditions.

Any use beyond the intended purpose or any deviation from the use described here is considered misuse and may lead to potentially hazardous situations. The manufacturer cannot be held liable for any resulting damage.

2.1.1 Product service life

The lifting columns are designed for a service life of 10000 double strokes at a stroke length of 300 mm (valid for a centric maximum load in accordance with the product label). During this period, the lifting column is maintenance-free. If other service life requirements exist, internal testing must be carried out.

2.2 Unintended use

Any use other than the intended use, or any modification to the device without the manufacturer's written consent, is not permitted. Operation beyond the technical limits is also not permitted.

The technical operating limits can be found in the *Technical data* chapter of this manual and on the device type plate.

The lifting columns are suitable for indoor use only and must not be exposed to weather conditions, strong radiation fields, and corrosive or explosive atmospheric media, see chapter *Ambient conditions*.

The following environments in particular are not suitable for operation:

- explosive environment
- flammable anesthetic gas mixture with air
- flammable anesthetic gas mixture with oxygen or nitrous oxide
- strong radiation fields
- outdoor environments or areas exposed to water (damp rooms)

Any unauthorized use of the device can cause personal injury and property damage. The instructions in this user manual must be observed at all times.

Neither the design nor individual components of the lifting column may be modified.

2.3 Responsibility of the owner and processor

The device is intended for both private use and use in commercial applications by the owner or processor.

The processor is the contractual partner of the reseller or the manufacturer. The processor installs the device in a complete system (application).

The owner or processor of the system is subject to the requirements of the Occupational Health and Environmental Act.

In addition to the safety instructions in this manual, the owner or processor must observe the following in relation to these safety regulations, accident prevention guidelines, and environmental protection regulations applicable at the system's installation site:

- Familiarize themselves with the applicable occupational health and safety regulations and, by means of a risk assessment, identify any additional hazards arising from the specific working conditions at the device's place of use. Implement the hazard assessment in the form of work instructions for operating the device.
- Confirm that the work instructions created for the system, including the device, comply with current legal requirements, and adapt the instructions accordingly
- Clearly define and assign responsibilities for installation, operation, maintenance, and cleaning.
- Ensure that all personnel handling the device have read and understood this manual..
- Provide personnel with the required protective equipment.
- Train personnel regularly and inform them about the dangers.

In addition, the owner or processors must ensure that the device is in proper working condition. They must do the following:

- Ensure that the maintenance intervals described in this manual are observed.
- Have all safety devices checked regularly to ensure their correct operation and completeness.

2.4 Personnel requirements

Operator duties:

- Ensure that only qualified and authorized personnel carry out the activities described in these instructions.
- Ensure that personal protective equipment is used.

Only persons who can be expected to reliably perform their tasks are permitted. Persons whose ability to react is impaired, e.g., due to drugs, alcohol, or medication, are not permitted.

2.4.1 Qualifications

For the various areas of activity described in this manual, the following qualifications are required:

Operator

The operator has been instructed by the customer on the assigned tasks and possible hazards in the event of improper conduct.

Qualified personnel

Qualified personnel meet the following criteria:

- Product knowledge, e.g. by receiving training on how to use the product
- are fully familiar with the contents of this manual and, in particular, with all of the safety instructions
- are familiar with the relevant country-specific regulations

Qualified personnel, on the basis of their technical training, knowledge, and experience as well as familiarity with the applicable standards and regulations, are capable of performing the work assigned to them and of independently recognizing and avoiding potential hazards.

Electrically skilled person

An electrically skilled person, on the basis of their technical training, knowledge, and experience as well as familiarity with the applicable standards and regulations, is capable of performing work on electrical systems and of independently recognizing and avoiding potential hazards.

The electrically skilled person is trained for the specific place of use and is familiar with the applicable standards and regulations.

2.5 Protective equipment

For certain work on the product, suitable protective equipment must be worn. Personal protective equipment consists of:

3 Required personal protective equipment

Personal protective equipment	Mandatory signs in accordance with DIN EN ISO 7010
Safety shoes	

2.6 Hazards

This section lists the residual risks identified during the risk assessment.

Observe the safety instructions listed here and the warning notices throughout this manual to reduce the risk of personal injury and property damage, and to avoid hazardous situations.

Danger to life from electric current

Touching live parts poses an immediate danger to life. Damage to insulation or individual components may pose a danger to life. Therefore, observe the following:

- If the insulation is damaged, immediately switch off the power supply and have the parts repaired.
- Work on the electrical system may only be performed by professional electricians.
- Before performing any work on the electrical system, disconnect the machine from the power supply.
- Before maintenance, cleaning, or repair work, disconnect the power supply and secure it against reconnection.
- Do not bypass or disable fuses. When replacing fuses, ensure the correct current rating is used.
- Keep moisture away from live parts. to prevent short circuits.

Risk of injury due to moving components

Moving parts may cause serious injuries. Therefore, observe the following:

- Do not work on moving components.
- Keep your entire body, hands, and arms away from moving components.

2.7 Safety regulations

The following safety regulations must be observed when working with the product. You can find further information on dangers and specific instructions in other chapters, including those entitled Installation, Commissioning, Operation, and Maintenance.

2.7.1 Safety equipment

-  The lifting column has no built-in operating status indicator. For applications in the medical field, an operating-status indicator is mandatory.

Integration of an emergency shut-off system (for certain applications)

The device is intended exclusively for installation in an application or system. The device does not have its own operating elements and has no independent emergency-stop device. Observe the following:

- Install the device so that it is part of an emergency shut-off system and can be stopped if necessary.
- The emergency shut-off system must be connected in such a way that an interruption of the power supply, or restoration of the power supply after an interruption, does not pose a hazard to persons or property.
- Emergency shut-off systems must be freely accessible at all times.

-  It is the processor's responsibility to determine whether the installation of an emergency shut-off system is required for an application.

Integration of an emergency adjustment (for certain applications)

The device is intended exclusively for installation in an application or system. The device does not have its own operating elements or an additional manual emergency adjustment for operating the lifting column. In the event of a malfunction, the device cannot extend or retract.

If required by the application, a separate device for manual adjustment must be provided to ensure safe raising or lowering of the patient in the event of an emergency or device failure.

-  The processor determines which applications require manual adjustment for the patient.

Anti-pinching protection (optional)

To increase safety, optional anti-pinching protection can be connected.

-  It is the processor's responsibility to determine whether the installation of anti-pinching protection is required for an application.

Installed safety devices

The following safety devices are already installed:

- **Thermoswitch:**
The lifting column is equipped with a thermoswitch. The thermoswitch integrated into the transformer shuts down the lifting column in the event of excessive temperature. For lifting column TXG10, the control unit used must provide thermal protection.
- **Limit switches:**
Limit switches ensure safe power interruption when the end position is reached. If the limit switches fail, an additional limit switch prevents the device from exceeding its intended stroke.

2.7.2 Safeguarding against restart

When working in hazard zones, there is a risk that the power supply could be turned on without prior authorization. Uncontrolled reconnection represents a potentially life-threatening situation for people within the danger zone.

Observe the following:

- Follow the instructions provided in this user manual on preventing uncontrolled reconnection of the power supply.
- Follow the steps described below to secure against reconnection.

Securing the lifting column (AC versions) against unauthorized reconnection

Remove the mains plug from the socket.

Securing lifting column TXG10 (DC version) against unauthorized reconnection

Remove the mains plug of the EWELLIX control unit or the mains plug of the master lifting column from the socket.

2.7.3 Modifications to the device

- ⚠ To avoid hazardous situations and to ensure optimal performance, do not make any changes or modifications to the device that have not been specifically authorized by Schaeffler.

2.7.3.1 Warning labels

Symbols and warning signs are located in the hazard zone. They refer to the immediate surroundings.

For the meaning of the symbols and signs, see chapter *About the manual*.

Stickers and warning signs may become dirty or illegible over time or for other reasons. Please observe the following:

- Ensure that all safety instructions, warning notices, and operating instructions remain legible at all times.
- Replace damaged stickers and warning signs

2.7.4 Spare parts

The lifting column is not designed for repair work by the user. Any warranty or service claims will be rendered invalid immediately, without prior notice, if any screws on the device have been tampered with.

Safety risk due to incorrect spare parts

The use of incorrect or defective spare parts can compromise safety and lead to damage, malfunctions, or complete failure. Observe the following:

- Only use original spare parts from the manufacturer.
- Spare parts in or on the device may only be replaced by the manufacturer. The device must be dismantled and sent to the manufacturer.

If the device cannot be repaired on site by authorized personnel, it must be removed from the application and sent to the manufacturer.

2.7.5 Work on electrical devices

Work on the electrical system may only be carried out by professional electricians.

Wiring, opening, and closing of electrical connections may only be performed when the system is disconnected from the power supply and in a voltage-free state.

2.7.6 Transport and storage

The product may only be transported and stored in its original packaging and under the permissible ambient conditions, see *Technical data*.

Damage due to improper transport

Proceed with caution when unloading the packaged goods, during delivery, and during transport to the destination. Observe the symbols and instructions on the packaging. Do not remove the product from the packaging until immediately before installation.

2.7.7 Operation

The product is intended for intermittent operation or short-time operation: For the permissible duty cycle, see table *Technical data*. If a higher duty cycle is required, Schaeffler must be contacted.

The lifting column is maintenance-free throughout its service life.

Risk to life and property damage due to collisions

Ensure that no persons remain in the stroke area of the device during operation and that no objects are located within the stroke area.

Do not tamper with connected components while the device is in operation.

The load limits of the lifting column must not be exceeded. Exceeding the permissible values can result in serious injury and property damage. Observe the specified load limits, see *Technical data*.

The product may only be operated under the permissible ambient conditions and within the defined specifications, see *Technical data*.

Damage due to penetrating liquids

Keep liquids away from the device during operation.

The protection code (IP) is only guaranteed if the lifting column is installed in the finished unit and mounted correctly.

3 Scope of delivery

The lifting column is delivered as a unit, packaged either in a cardboard box or on pallets.

Scope of delivery of the EWELLIX TXG lifting column:

- 1 complete lifting column
- 8 fastening screws DIN 7500 M6×40
- for slave only: 1 connection cable
- 1 user manual BA 121

Accessories

The following accessories are not included in the scope of delivery and must be ordered separately:

- cable for electrical anti-pinching protection
- 1 EWELLIX operating element: hand switch, desk switch, foot switch, see tables in Technical data
- for TXG10: 1 EWELLIX control unit
- 1 mains cable, 2-pin or 3-pin, country-specific
- mounting plates, clear anodized

3.1 Check for damage during transit

1. Check the product immediately upon delivery for any damage during transit.
2. Do not accept delivery, or only accept it with reservation, if transport damage is found.
3. Record the extent of damage on the transport documents or the carrier's delivery note.
4. Report any damage during transit promptly as a complaint to the carrier.

 Report any damage as soon as it is discovered. Claims for damages can only be made within the applicable claim period stipulated by the transport company.

3.2 Check for defects

1. Check the product immediately upon delivery for any visible defects.
2. Check the product for completeness immediately upon delivery.
3. Report any defects promptly to the distributor of the product.
4. Do not put damaged products into operation.

4 Product description

The EWELLIX TXG lifting column is an electric linear actuator that operates with virtually play-free guide tubes. The lifting column is designed for holding and moving centric and off-centric loads.

A DC motor drives a threaded spindle via a bevel gear. A threaded nut moves up and down on the spindle and is firmly connected to the push tube, thereby generating the feed motion. The guide tubes extend or retract depending on the motor's direction of rotation.

In versions with a mains connection (stand-alone and master), the mains voltage is transformed to 24 V and rectified. The slave lifting column is a 24 V DC actuator.

4

1 Lifting column TXG

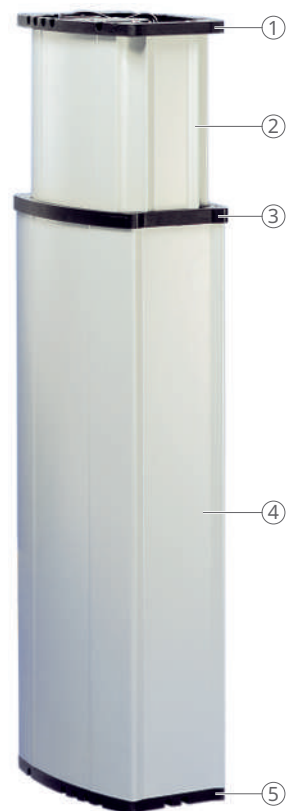

001C3310

1	Base plate of the inner tube	2	Inner tube
3	Rim cover	4	Outer tube
5	Base plate of the outer tube		

Definition of terms

Stand-alone: Lifting column with integrated control unit and power supply, used as a single lifting column.

Master: Lifting column with integrated control unit and power supply, with the option to connect an additional lifting column.

Slave: Lifting column without integrated control unit and power supply. To be used in combination with a master lifting column or a separate control unit.

Master-slave: 2 lifting columns, where the master lifting column provides the control function and power supply for the slave (no parallel operation).

Thermoswitch

-  The lifting column is equipped with a thermoswitch. The thermoswitch integrated into the transformer shuts down the actuator in the event of excessive temperature. For lifting column TXG10, the control unit used must provide thermal protection.

If the duty cycle is exceeded, the lifting column may become temporarily inoperative. To reset the thermoswitch, disconnect the mains plug from the lifting column for approx. 1 min and allow it to cool down.

4.1 Control unit: Stand-alone and master

The DC motor is supplied via an integrated control unit, which is available in 2 versions:

The basic control board contains a relay circuit that controls the direction of travel of the actuators.

For lifting columns with the “parallel operation” or “memory function” option, control and regulation are handled by a microprocessor. These lifting columns are equipped with a pulse generator at the factory for position detection. If a slave lifting column is to be connected, it must also be equipped with a pulse generator.

Lifting columns with the “parallel operation” or “memory function” option also feature a soft-start function for smooth, jerk-free initiation of movement. The memory function option also provides a soft stop that decelerates the actuators before they reach the stored position.

The lifting column offers comprehensive protection against malfunctions. However, single-fault safety cannot be guaranteed, as unforeseeable malfunctions, for example, in a control unit, may lead to slow, uncontrolled movements.

-  It is, therefore, essential that the single-fault safety of the complete system be verified in the end device to ensure that hazards to persons or property are reliably prevented.

4.1.1 Requirements for third-party control units

Mandatory for medical applications when using a third-party control unit

The requirements apply to TXG10 versions (stand-alone).

Control units that are not approved by Schaeffler for TXG are treated as third-party control units.

Requirements for third-party control units:

- isolation from the mains by 2 MOPPs
- over current cut off
- “push-to-run” operation (recommended): The actuator operates as long as the switch is pressed down.
- operating status indication

4.2 Terminal-position shutdown

The stroke of the lifting column is limited by built-in limit switches that switch off the lifting column.

If a malfunction occurs and a limit switch is overrun, an additional safety limit switch is activated. The actuator circuit is interrupted; the lifting column can no longer be extended or retracted and must be repaired.

4.3 Connections

2 Connections on lifting column TXG

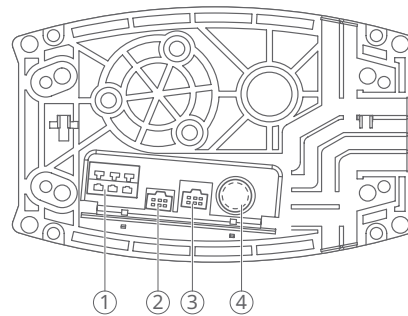

001 C3320

1	For mains cable (N, L, PE)	2	For electrical anti-pinching protection (option)
3	For operating element (10-pin RJ45)	4	For 2nd lifting column for master-slave operation (option, DIN-8 plug)

4.4 Operating element

TXG10 (stand-alone)

The lifting column does not have its own operating element. Operation is enabled via an EWELLIX operating element connected to an EWELLIX operating element.

All variants except TXG10

The lifting column does not have its own operating element. Operation is enabled via an EWELLIX operating element that is connected directly to the lifting column. Observe the separate user manual for the operating element.

Requirements for operating elements (required for medical applications)

General safety requirements in accordance with IEC 60601-1.

For suitable EWELLIX operating elements, see chapter Accessories.

4.5 Options

- mains cable feed through, max. load: 250 V, 50 - 60 Hz, 6 A
Lifting column is double-insulated. The protective earth conductor is routed through but is not connected to the metal parts of the lifting column.
- control cable feed through
- connection for 2nd lifting column (master-slave operation)
- guide tubes, powder-coated
- connection for electrical anti-pinching protection

 Protection class II applies as standard to the lifting column. For the version with mains cable feed through, protection class I applies with a routed-through protective earth conductor. The mains cable feed through is protected on both sides by 2× 6.3 A slow-blow fuses. The aluminum guide tubes are not connected to the protective earth conductor.

4.6 Required accessories

4 Required accessories

Accessories	Comments
Cable for electrical anti-pinching protection	To increase safety, anti-pinching protection can be connected (optional).
EWELLIX operating element	Hand switch, desk switch, or foot switch, see tables in Technical data
Mains cable	2-pin or 3-pin, country-specific
Mounting plates, clear anodized	The mounting plates are used to securely fasten the lifting column to the application and to optimally support the load introduction points on the column. The lifting column can be mounted either on Schaeffler mounting plates or on customer-supplied plates.

 Schaeffler accepts no liability for any damage resulting from the lifting column not being used with a suitable Schaeffler operating element or Schaeffler accessories.

The use of accessories or cables other than those recommended by Schaeffler for this device may result in increased emissions or reduced immunity of the device.

Details on accessories can be found in the section Accessories

5 Transport and storage

NOTICE



Damage due to improper transport

Improper transport may result in significant property damage.

- Proceed with caution when unloading the packaged goods, during delivery, and during transport to the destination.
- Observe the symbols and instructions on the packaging.
- Do not remove the product from the packaging until immediately before installation.
- Observe the ambient conditions for return transport to the manufacturer.

5.1 Transport

Observe the safety regulations for transport.

Requirements for packaging

Each individual packaged part must be packed appropriately for the anticipated transport conditions. Only environmentally friendly materials may be used for the packaging.

The packaging is intended to protect the individual components from transport damage, corrosion, and other types of damage until assembly.

1. Do not destroy the packaging and only remove it shortly before assembly.
2. Keep the packaging in case the product needs to be returned to the manufacturer ►21 | 5.3.

Packaging material consists of valuable raw materials, most of which can be effectively recycled and reused.

If the packaging is to be disposed of following intact delivery, the following instructions must be observed and complied with:

3. Dispose of packaging material in an environmentally responsible manner.
4. Observe the locally applicable disposal regulations.

5.2 Storage

Observe the safety regulations for the storage.

1. Store the product in its original packaging and avoid mechanical shocks.
2. If the storage period is ≥ 3 months, regularly check the general condition of all packaging components.
3. Follow any additional storage instructions detailed on the packaging.

5.3 Return to the manufacturer

Proceed as follows for return transport:

1. Dismantle the device if necessary.
2. Pack the device in its original packaging.
3. Observe the safety instructions for transport and storage ►14 | 2.7.6.
4. Send to the manufacturer. The address is provided on the back of this operating manual.

6 Mounting

Observe the technical data in accordance with the operating conditions.
Comply with all safety regulations.

Authorized personnel

- Assembly and commissioning may only be carried out by qualified technical personnel.
- Work on the electrical system may only be carried out by trained, electrically skilled persons.

Safety instructions

DANGER



Risk of serious or fatal injuries from live components and moving parts

Serious or fatal injuries may result from contact with live components or from unexpected movement of the lifting column.

- Switch off the power supply and secure it against unintentional reconnection before performing any work on the system.

DANGER



Risk of fatal injury from unauthorized reconnection of the power supply

Risk of fatal injury to persons in the hazard area due to moving parts or electric shock if the power supply is switched on without authorization during work on the system and causes the system to restart.

- Before starting work, switch off the system and secure it against reconnection.

WARNING



Risk of injury and equipment damage due to improper installation of optional devices

Risk of injury and property damage if optional devices are installed improperly.

- Install optional devices, particularly components used in retrofits, only in accordance with the respective instructions (circuit diagram).
- Check the electromagnetic compatibility for the installation and, if necessary, take appropriate measures as described in the user manual for the device.

6.1 Installing the lifting column

Follow the supplied mounting instructions during installation.

The lifting column can be mounted either on Schaeffler mounting plates (see chapter *Accessories* ▶52 | 14.2) or on customer-supplied plates. Plastic base plates are attached to the end faces of the outer tube and inner tube.

The mounting plates are attached to the aluminum tubes via 4 holes in each base plate using the pre-pressed holes. Use only the supplied fastening screws for mounting.

WARNING



Risk of objects or body parts becoming trapped during retraction

During retraction, objects or body parts may become trapped between the mounting plate of the inner tube and the outer tube. Risk of crushing and risk of injury or property damage.

- ▶ Ensure that no objects or body parts can become trapped between the mounting plate of the inner tube and the outer tube during retraction.

WARNING



Grounding metallic mounting plates through the lifting column

If metallic mounting plates are grounded through the lifting column, there is a risk of injury and property damage.

- ▶ Do not ground metallic mounting plates through the lifting column. If necessary, ground or insulate metallic mounting plates outside of the lifting column.
- ▶ When using auxiliary devices that do not conform to protection class II: Connect the mounting plate to the protective earth conductor.

NOTICE



Damage due to under-dimensioned mounting plates

If the base plates are not supported over their entire surface, there is a risk of the base plates breaking.

- ▶ Use suitable mounting plates, see *Accessories*.
- ▶ Customer-supplied mounting plates must be sufficiently dimensioned to provide full-surface support for the base plates and distribute the load evenly across the entire surface.

NOTICE



Falling chips when cutting threads

The lifting column may be destroyed by falling chips.

- ▶ Do not cut threads into the holes using a tap.



Any additional mounting holes in the aluminum guide tubes may only be made by Schaeffler.

The side walls of the inner tubes must not be scratched, as this may damage the gliding elements. A damaged gliding surface may result in malfunctions.

1. Apply a small quantity of grease to the fastening screws before tightening them.
2. Attach the mounting plates to the aluminum tubes using 4 fastening screws: screw into the aluminum tubes to a minimum depth of 25 mm. Fasten the outer tube using the outer holes and the inner tube using the inner holes.

Observe the required tightening torque: 9 Nm to 11 Nm

- » When the fastening screws are tightened for the first time, a thread is formed in the pre-pressed holes of the aluminum tubes.

NOTICE



Unsuitable fixing holes

The base plates may break if the incorrect fixing holes are used.

- ▶ Fasten the outer tube using the outer holes.
- ▶ Fasten the inner tube using the inner holes.

3 Mounting the lifting column on the outer tube

4× DIN 7500 M6×40
 $M_A = 9 \text{ Nm} \dots 11 \text{ Nm}$

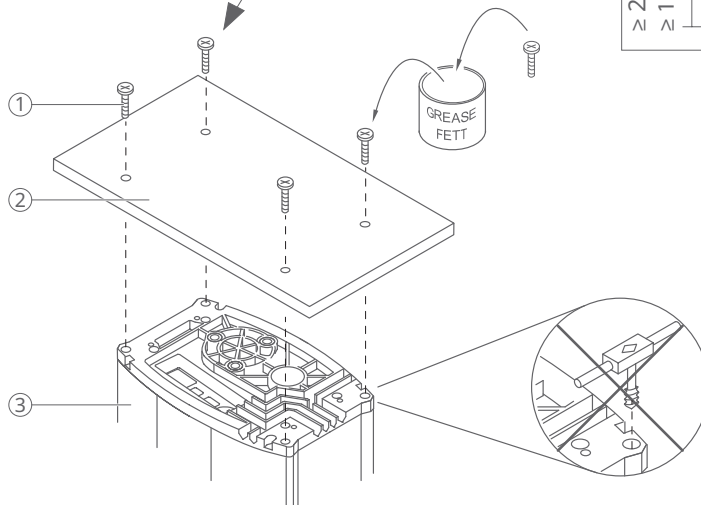

001C3330

1	Fastening screws	2	Mounting plate
3	Outer tube		

4 Mounting the lifting column on the inner tube

4× DIN 7500 M6×40
 $M_A = 9 \text{ Nm} \dots 11 \text{ Nm}$

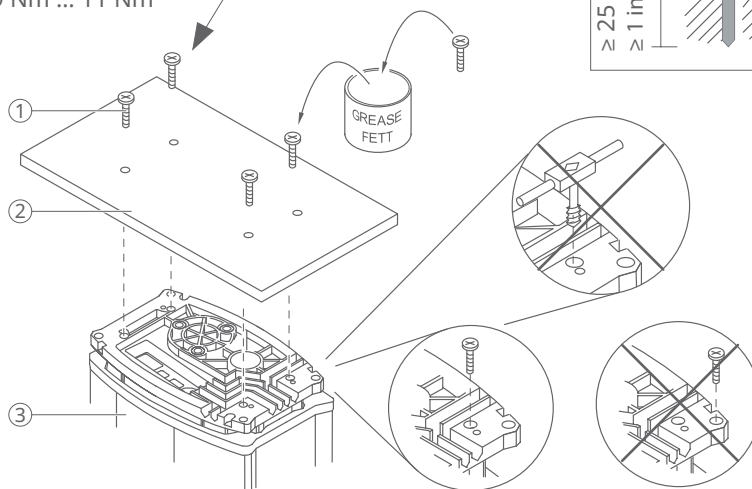

001C3380

1	Fastening screws	2	Mounting plate
3	Inner tube		

6.2 TXG10: Connecting to the control unit

This section applies to slave types of the lifting columns (TXG10) without an integrated control unit or power supply, which can be used with a separate external control unit.

All control units that are not approved by Schaeffler for the TXG lifting columns are treated as third-party control units.

NOTICE



Risk of product damage due to third-party control units

The use of third-party control units may result in property damage. The manufacturer accepts no liability for any damage that may occur in connection with the use of a third-party control unit.

Schaeffler recommends using the appropriate Schaeffler control unit, see Technical data. When using a third-party control unit, observe the requirements specified for third-party control units, see section *Requirements for third-party control units* ► 18 | 4.1.1.



The device is connected to the external control unit via a low-voltage plug (DIN-8 plug). When connecting, observe the instructions provided in the user manual for the EWELLIX control unit.

1. Using the power cable, connect the external control unit to the 8-pin socket marked "slave".
2. Ensure that the plug is inserted in the correct orientation. The notch must face upward.

5 Connecting the control unit

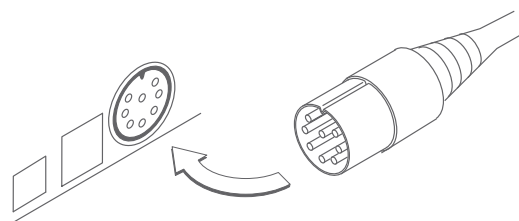

001C31A7

3. Observe any additional connection instructions provided in the user manual for the external control unit where applicable.

6.3 Connecting the operating element

⚠ WARNING



Third-party operating elements

The use of third-party operating elements may result in serious injury or property damage. The manufacturer accepts no liability for damage resulting from the use of third-party operating elements.

- Always use only suitable EWELLIX operating elements from Schaeffler.
- When using auxiliary devices that do not conform to degree of protection II, the fixation plate must be connected to the protective conductor.

6.3.1 Connecting the operating element for lifting column TXG10

The device is connected to the operating element via an external control unit.

1. Observe the separate user manual for the control unit.
2. Observe the separate user manual for the operating element.

6.3.2 Connecting the operating element to the lifting column (all types except TXG10)

The device is connected directly to an operating element.

1. Observe the separate user manual for the operating element.
2. Insert the plug of the operating element into the socket, see figure Connections ►19 | ⑥2 (3).
3. Ensure that the notch on the plug engages with an audible click.

⑥6 Connecting the operating element

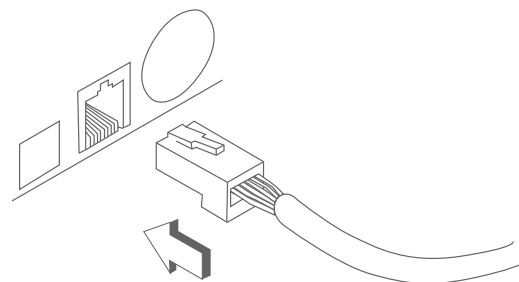

001C3191

6.4 Connecting the mains cable

6.4.1 TXG10 (stand-alone): Connecting the control unit to the power supply

The device is connected to the operating element via an external control unit.

1. Observe the separate user manual for the control unit.
2. Observe the separate user manual for the operating element.
- ✓ The lifting column is connected to the control unit, see connections in Figure ►19| 2 (3).
3. Connect the control unit to the mains supply, observing the separate user manual for the external control unit.
4. Ensure that the mains cable plug remains accessible at all times.

6.4.2 Connecting the lifting column (all types except TXG10) to the power supply



DANGER

Improper installation

Electric shock

- ▶ Only qualified electricians are permitted to work on electrical systems.



When using customer-supplied mains cables, observe the following specifications:

H0W-FVDE 0.75 mm², stranded wires stripped 5 mm to 6 mm.

Connecting the mains cable:

1. Connect the mains cable to the designated connector,
2. observing the stranded wire assignment. The terminal for the protective earth conductor is only installed for the optional mains cable feed through.

7 Mains connection

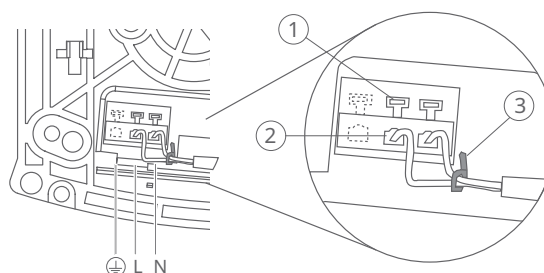

001C31B2

1	Clamp lever	2	Terminal opening
3	Cable tie		Protective conductor connection (only with mains cable feed through option)
L	Phase conductor connection	N	Neutral conductor connection

Inserting the individual stranded wires:

3. Press the clamp lever downward using a size 1 screwdriver.
4. Insert the stripped wire into the terminal opening.
5. Release the clamp lever.

DANGER Risk of electric shock due to loose cable

If wires become detached from the terminal, there is a risk of electric shock due to high leakage current.

- Secure the stranded wires using a cable tie.



- To secure the stranded wires, attach a cable tie as close to the terminal as possible.

Each L and N conductor in the circuit is protected by 1 fuse. If one or both fuses blow, the lifting column must be replaced.

The lifting column can also be ordered without internal fuses. In this case, the customer is responsible for correct electrical protection: 2 fuses, max. 6.3 A

Mains cable feed through (optional)

The protective earth conductor must be ≥ 20 mm longer than the other wires to ensure the protective function.

DANGER Connecting multiple mains cables

Destruction of the lifting column may occur if multiple mains cables are connected. Risk of electric shock.

- Always connect 1 mains cable only, either at the top or at the bottom.



6.5 Connecting the 2nd lifting column for master-slave operation (optional)

NOTICE Product damage to the master lifting column due to incorrect master-slave combination

Connecting a slave lifting column without the encoder option to a master lifting column with the "parallel operation" or "memory function" option may result in destruction of the master lifting column.

- Only a slave lifting column with the encoder option may be connected to a master lifting column with the "parallel operation" or "memory function" option.



NOTICE Product damage to the slave lifting column due to incorrect master-slave combination

Connecting a slave lifting column with an encoder to a master lifting column without the "parallel operation" or "memory function" option may result in destruction of the slave lifting column.

- Do not connect a slave lifting column with the encoder option to a master lifting column without the "parallel operation" or "memory function" option.



- Connect the 2nd lifting column to the 8-pin socket marked "slave" using the connection cable.
- Ensure that the plug is inserted in the correct orientation. The notch must face upward.

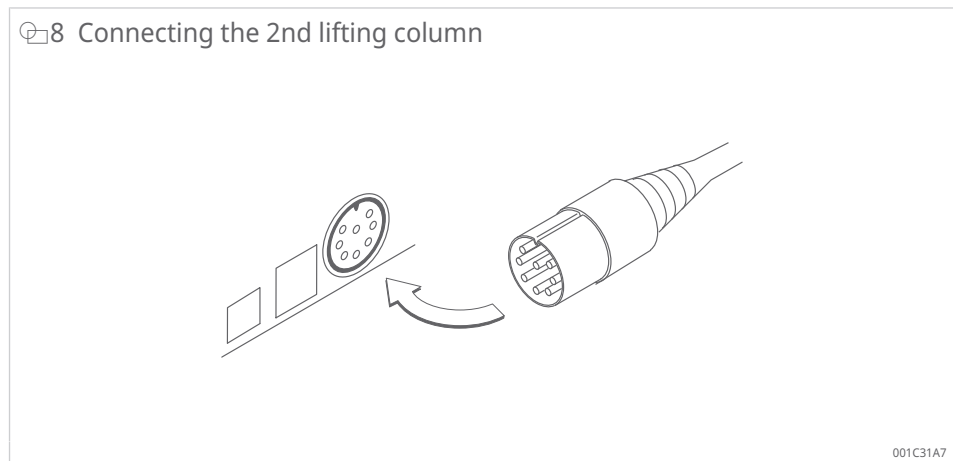

6.6 Establishing strain relief

The required strain relief is ensured when all cables are routed to the outside through the designated channels in the base plate.

Depending on the application, the cables may be routed to the rear (A1) or to the side (B). If the cables are routed to the front (A2), the outgoing mains cables require separate strain relief. The narrow channels are suitable for cable diameters of 4.5 mm to 5.5 mm; the wider channels are suitable for cable diameters of 5.5 mm to 7.5 mm.

For strain relief requirements in accordance with IEC 60601-1, the following applies:

- cable with 2 conductors ($2 \times 0.75 \text{ mm}^2$): narrow channel B is suitable.
- cable with 3 conductors ($3 \times \text{AWG}$): channels A1 and B are suitable.

! Electrical cables must not be crushed and must not be subjected to bending loads or pull loads.

! If you do not route the cables through the channels, or if you route them to the front (A2), you must ensure adequate strain relief through appropriate design measures.

1. Route all cables to the outside through the cable channels in the base plate.
2. If the cables are routed to the front (A2): secure the outgoing mains cables with additional strain relief.

9 Cable routing

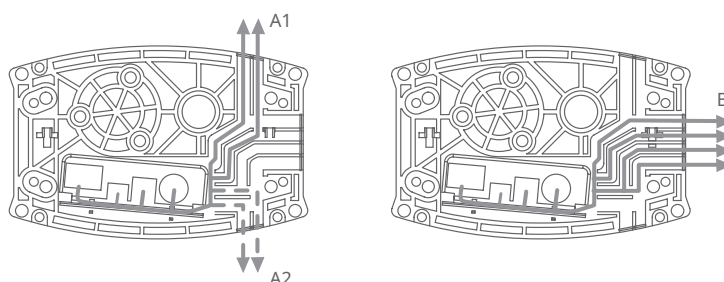

001C3193

A1	Cable routing to the rear	A2	Cable routing to the front
B	Cable routing to the side		

7 Commissioning

Observe the technical data in accordance with the operating conditions.

Comply with all safety regulations.

The lifting column without additional functions, such as parallel operation or memory function, is ready for operation after correct electrical and mechanical installation.

Before the lifting column can be used in parallel operation or with the memory function, an initialisation run must be performed once.

Operation of the lifting columns can be carried out using various operating elements, depending on the requirements.

The following describes operation using the EWELLIX STA desk switch as an example. For an explanation of the buttons, see table ►33 | 5.

Authorized personnel

- Assembly and commissioning may only be carried out by qualified technical personnel.
- Work on the electrical system may only be carried out by trained, electrically skilled persons.

7.1 Inspections prior to initial commissioning

A professional electrician must carry out and document the following inspections and measurements before initial startup:

1. Visual inspection of the condition.
2. Check operating and safety functions.
3. Measure leakage currents.
4. Measure insulation resistance.

Further information on inspections and measurements is provided in the chapter *Maintenance*.

7.2 Performing the initialisation run for parallel operation

1. Using the direction buttons [Up] and [Down] on the operating element, move the lifting columns once to the end position (= reference point) in the counter-load direction.
2. Keep the button pressed until all lifting columns have reached the end position and stop.



If the initialization run is not carried out in parallel operation, the control assumes that the lifting columns are synchronized and will operate with an offset.

7.3 Performing the initialisation run for the memory function

1. Using the direction buttons [Up] and [Down] on the operating element, move each lifting column individually once to the end position (= reference point) in the counter-load direction.
2. Keep the button pressed until the lifting column has reached the end position and stops.

- ! If the initialization run is not carried out when using the memory function, the lifting column will move to the end position in the counter-load direction when the direction buttons are pressed. When the [M] button is pressed, a pulsing acoustic signal is emitted.

8 Operation

The product is intended for intermittent operation or short-time operation: For the permissible duty cycle, see table *Technical data*. If a higher duty cycle is required, Schaeffler must be contacted.

Safety instructions

DANGER



Risk to life and property damage due to collisions

A collision of the lifting column with persons or fixed objects can result in life-threatening injuries or property damage due to the force of the actuator.

- Ensure that no persons remain in the stroke area of the device during operation.
- Observe the maximum permissible operating data of the device, see *Technical data*.
- Do not tamper with connected components while the device is in operation.

NOTICE



Risk of equipment damage due to static or dynamic overload

Risk of damage to or failure of the device

- Do not overload the lifting column or actuator or operate it outside the permissible operating data; see *Technical data*.
- Do not exceed the rated load.
- Do not tamper with connected components while the device is in operation.

NOTICE



Ingress of fluids

The device may become damaged if liquids penetrate the actuator during extension or retraction.

- Keep liquids away from the device during operation.

8.1 Implementing protective measures

1. Comply with all safety regulations and safety instructions.
2. Observe the technical data in accordance with the operating conditions.
3. Ensure that no persons or objects are located in the stroke area of the device.

8.2 Switching on

Switching on the TXG10 lifting column (stand-alone)

The lifting column does not have its own operating element. Operation is enabled via an EWELLIX operating element connected to an EWELLIX operating element.

- ✓ The lifting column is connected to the control unit.

1. Observe the separate user manual for the control unit.
2. Observe the separate user manual for the operating element.

Switching on the lifting column (all types except TXG10)

1. Observe the separate user manual for the operating element.

Once the lifting column is connected to the power supply and the operating element (see *Installation*), it is ready for operation.

8.3 Switching off

Switching off the TXG10 lifting column (stand-alone)

The lifting column does not have its own operating element. Operation is enabled via an EWELLIX operating element connected to an EWELLIX operating element.

1. Observe the separate user manual for the control unit.
2. Observe the separate user manual for the operating element.

Switching off the lifting column (all types except TXG10)



1. Remove the mains plug.

8.4 Actions during operation

Operation of the lifting columns can be carried out using various operating elements, depending on the requirements.

The following describes operation using the EWELLIX STA desk switch as an example. For an explanation of the buttons, see table ►33 | 5.

5 Explanation of the buttons on the operating element

Button	Description of the function	
	[Up]	Lifting column extends.
	[Down]	Lifting column retracts.
	[M]	Store memory position.

8.4.1 Actuating a single lifting column (stand-alone operation)

Use the [Up] and [Down] direction buttons on the operating element to actuate a lifting column directly.

1. To extend the lifting column: press the [Up] button.
2. To retract the lifting column: press the [Down] button.
 - » The lifting column will move until you release the control button or an end position is reached.

10 Single operation

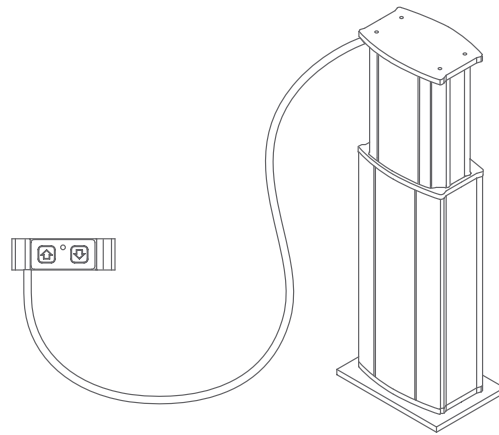

001C3196

8.4.2 Actuating lifting columns in parallel operation (parallel operation option)

Use the [Up] and [Down] direction buttons on the operating element to actuate all lifting columns directly. Only 1 pair of buttons is required for parallel operation. All lifting columns move simultaneously.

Parallel operation also includes a memory function ▶35 | 8.4.3.

NOTICE



Overload in parallel operation

Damage in the event of overload

› The maximum load in parallel operation must not exceed the maximum load of a single lifting column. For the permissible maximum load, see Technical data.

1. To extend all lifting columns: press the [Up] button.
2. To retract all lifting columns: press the [Down] button.
 - › The lifting columns will move simultaneously until you release the control button or an end position is reached.
3. If an offset between the lifting columns occurs over time, repeat the initialization run for parallel operation ▶30 | 7.2.

11 Parallel operation

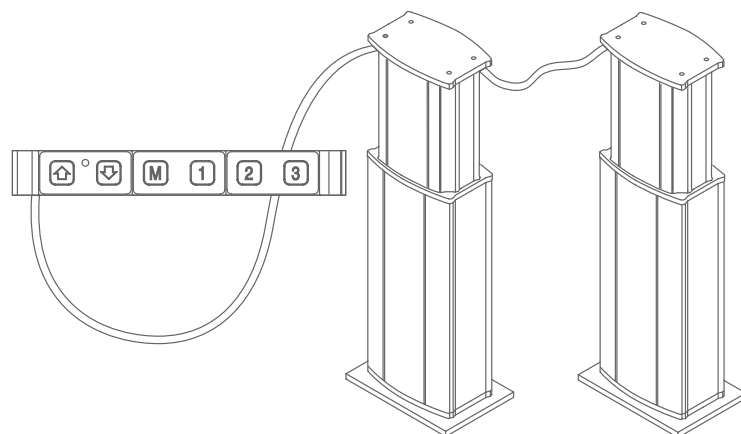

001C3197

8.4.3 Using the memory function

Using the [1] to [3] buttons on the operating element, positions can be recalled that were previously stored under these buttons in the integrated control unit.

Storing memory positions

1. Use the [Up] and [Down] direction buttons to move all lifting columns to the position you want to store under button [1].
Keep the buttons pressed until the desired position is reached.
2. Press and hold the [M] button, then additionally press the [1] button.
3. Release both buttons to store the position.
 - › An acoustic signal confirms that the position has been stored.
4. If necessary, repeat the procedure with buttons [2] or [3] to program the memory position for [2] or [3].
5. If an offset between the lifting columns occurs over time, repeat the initialization run for the memory function ►30 | 7.3.

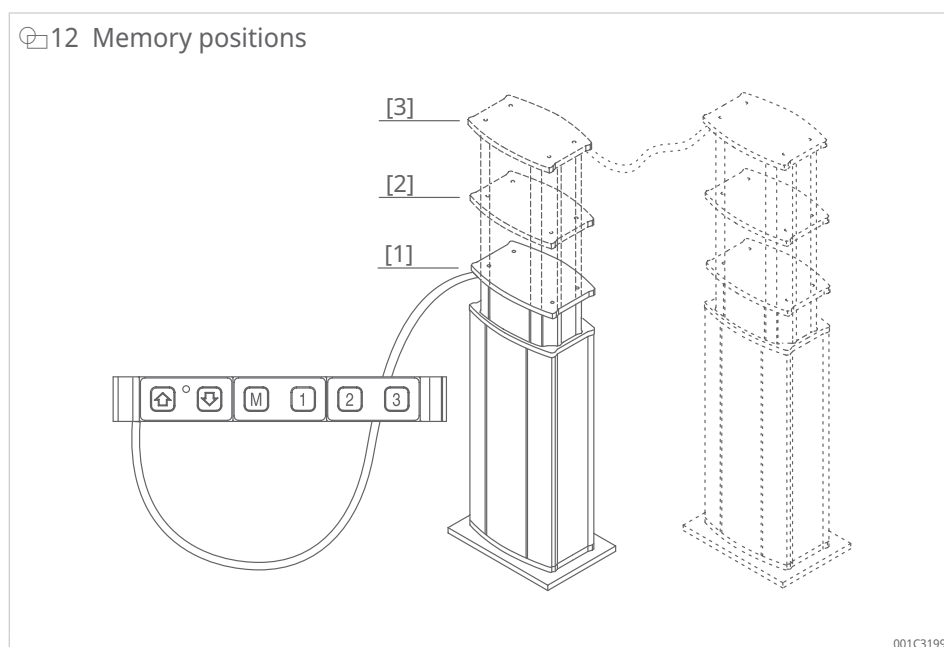

Recalling memory positions

6. To recall a memory position, press the corresponding button [1], [2], or [3] on the operating element.
7. Keep the button pressed until the lifting columns have moved to the position.

8.4.4 Working in master-slave operation

Use the [Up] and [Down] direction buttons on the operating element to actuate the master lifting column and the slave lifting column independently of each other.

NOTICE



Simultaneous control with master without parallel operation or memory function

Overload and potential damage to the control if the lifting columns are actuated simultaneously and the master lifting column is not equipped with a microprocessor control for parallel operation or memory function

» If the master does not support parallel operation or the memory function: actuate the lifting columns one after the other.

1. To extend the lifting column: press the [Up] button.
2. To retract the lifting column: press the [Down] button.
- » The lifting column will move until you release the control button or an end position is reached.

13 Master-slave operation

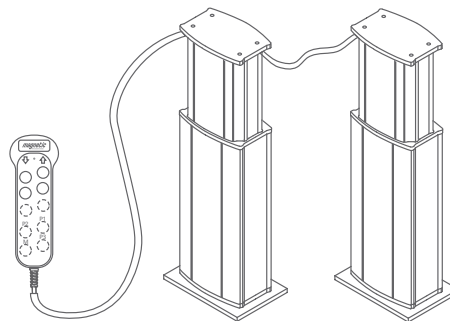

001C319B

8.5 Emergency disengagement

The lifting column has no built-in on/off switch and must be disconnected from the mains supply. The device can only be de-energized by disconnecting it from the mains supply.

The application in which the lifting column is installed must be equipped with an emergency-stop switch or provide isolation from the mains supply on all poles.

In hazardous situations, all movements of the device must be stopped as quickly as possible and the power supply must be disconnected.

Procedure in hazardous situations

1. Press the emergency-stop switch immediately, if available, or interrupt the power supply to the lifting column.
2. Evacuate all persons from the danger zone and initiate first aid measures.
3. If necessary, notify a doctor and the fire department.
4. Inform the responsible person on site.
5. Keep access routes clear for rescue vehicles.
6. Depending on the severity of the emergency, notify the relevant authorities if necessary.
7. Assign qualified personnel to rectify the fault.

⚠ DANGER**Risk of fatal injury due to improper restart**

Risk of fatal injury to persons in the danger zone, risk of property damage

- Do not restart the device until all persons are outside the danger zone.
- Check the device and the application that uses the device before resuming operation.
- Ensure that all safety devices are installed and fully functional.

1. Before restarting: Check the device and the application that uses the device, and ensure that all safety devices are installed and fully functional.

8.5.1 Disconnecting the TXG10 lifting column (stand-alone or slave) from the control unit

1. If stand-alone: disconnect the DIN-8 plug from the control unit in use.
2. If slave: disconnect the DIN-8 plug from the corresponding master lifting column.

 14 Shutting down lifting column TXG10

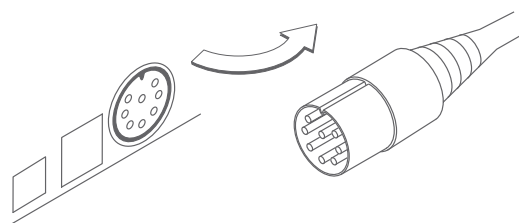

001C3195

8.5.2 Disconnecting the lifting column from the power source (all types except TXG10)

- Remove the mains plug from the power source.

9 Troubleshooting

The following chapter describes possible causes of device malfunctions and the measures required to restore operation.

If malfunctions occur frequently, shorten the maintenance intervals.

If a malfunction cannot be rectified with the measures described, contact Schaeffler Service.

Authorized personnel

- The measures described here may be carried out by the operator unless otherwise specified.
- Some tasks may only be performed by qualified personnel; this will be explicitly stated in the relevant fault description.
- Work on the electrical system may only be carried out by trained, electrically skilled persons.

Safety instructions

DANGER



Risk of serious or fatal injuries from live components and moving parts

Serious or fatal injuries may result from contact with live components or from unexpected movement of the lifting column.

- Switch off the power supply and secure it against unintentional reconnection before performing any work on the system.

DANGER



Risk of fatal injury from unauthorized reconnection of the power supply

Risk of fatal injury to persons in the hazard area due to moving parts or electric shock if the power supply is switched on without authorization during work on the system and causes the system to restart.

- Before starting work, switch off the system and secure it against reconnection.

WARNING



Risk of injury and property damage due to improper troubleshooting

Improper troubleshooting may result in injury or property damage.

- Do not loosen any screws on the device.
- Do not open the device.
- If malfunctions cannot be resolved by following the instructions below, remove the lifting column and send it to Schaeffler for repair.

Procedure in the event of malfunctions

As a general rule:

1. For malfunctions that pose an immediate risk to persons or property, switch off the lifting column or the control unit immediately and secure it against reconnection.
 - The lifting column is secured against reconnection.
2. Determine the cause of the malfunction.
3. Depending on the type of malfunction: have the malfunction remedied by qualified personnel.
4. Inform the responsible persons on site about the malfunction.



Refer to the *Troubleshooting* table to determine who is authorized to remedy the malfunction.

9.1 Lifting columns with mains connection (master or stand-alone)

6 Troubleshooting

Error	Possible cause	Remedy	To be carried out by
Lifting column does not move.	No mains voltage available	▶ Check the power supply.	Professional electrician
	Poor plug contact or plug not properly inserted	▶ Insert the mains plug correctly or check the terminal connection.	Operator
	Mains cable or mains plug defective	▶ Check the power supply and mains cable for damage. ▶ Replace defective components if necessary.	Professional electrician
	Obstacle in the lifting column's stroke area	▶ Remove all obstacles from the stroke area.	Qualified personnel
	Incorrect load	▶ Measure the static and dynamic load and compare it with the information on the product label. ▶ If the load is exceeded, replace the device.	Qualified personnel
	Operating element faulty	▶ Identify a possible defect in the operating element. ▶ If necessary, replace the operating element.	Qualified personnel
	Motor defective	▶ Send the lifting column to Schaeffler.	Qualified personnel
Device service life exceeded.	▶ If a lifting column is more than 10 years old and has performed ≥ 10000 double strokes at a stroke length of 300 mm: replace the lifting column.	Qualified personnel	
The lifting column does not move.	Internal fuse defective	▶ Send the lifting column to Schaeffler.	Qualified personnel
The lifting column does not move.	The lifting column cannot be set in motion by any of the above measures.	▶ Replace the lifting column.	Qualified personnel
Actuator only runs in 1 direction.	Cut-off mechanism defective	▶ Send the lifting column to Schaeffler.	Qualified personnel
Individual function not working (parallel operation or memory function only).	Data loss	▶ Move the lifting column to the reference point: perform the initialization run ▶30 7.2 ▶30 7.3.	Qualified personnel
Connected third-party devices not functioning.	No mains voltage available	▶ Check the power supply.	Operator
	Poor connector contact	▶ Insert the mains plug correctly or check the terminal connection.	Operator
	Mains cable faulty	▶ Replace the mains cable.	Qualified personnel
	Internal fuse of the cable feed through defective	▶ Send the lifting column to Schaeffler.	Qualified personnel
Markedly reduced speed	Motor, gears, or nuts faulty	▶ Send the lifting column to Schaeffler.	Qualified personnel
Significantly increased running noise	Motor, gears, or nuts faulty	▶ Send the lifting column to Schaeffler.	Qualified personnel
Play in the guide system	Wear of the gliding elements	▶ Send the lifting column to Schaeffler.	Qualified personnel

9.2 Lifting columns TXG10 (slave or stand-alone)

7 Troubleshooting

Error	Possible cause	Remedy	To be carried out by
Lifting column does not move.	Poor plug contact or plug not properly inserted	<ul style="list-style-type: none"> Fit the plug correctly. 	Operator
	Obstacle in the lifting column's stroke area	<ul style="list-style-type: none"> Remove all obstacles from the stroke area. 	Qualified personnel
	Incorrect load	<ul style="list-style-type: none"> Measure the static and dynamic load and compare it with the information on the product label. If the load is exceeded, replace the device. 	Qualified personnel
	Control unit or operating element defective	<ul style="list-style-type: none"> Identify a possible defect in the control unit. If necessary, replace the control unit or operating element. 	Qualified personnel
	Motor defective	<ul style="list-style-type: none"> Send the lifting column to Schaeffler. 	Qualified personnel
	Device service life exceeded.	<ul style="list-style-type: none"> If a lifting column is more than 10 years old and has performed ≥ 10000 double strokes at a stroke length of 300 mm: replace the lifting column. 	Qualified personnel
The lifting column does not move.	The lifting column cannot be set in motion by any of the above measures.	<ul style="list-style-type: none"> Replace the lifting column. 	Qualified personnel
Lifting column not functioning.	Poor connector contact	<ul style="list-style-type: none"> Insert the mains plug correctly or check the terminal connection. 	Operator
	Connection cable defective	<ul style="list-style-type: none"> Replace the connection cable. 	Qualified personnel
	Motor defective	<ul style="list-style-type: none"> Send the lifting column to Schaeffler. 	Qualified personnel
Individual function not working (parallel operation or memory function only).	Poor connector contact	<ul style="list-style-type: none"> Ensure that the plug of the connection cable is correctly inserted. 	Operator
Actuator does not move.	Obstacle in the lifting column's stroke area	<ul style="list-style-type: none"> Remove all obstacles from the stroke area. 	Operator
	Incorrect load	<ul style="list-style-type: none"> Remove load from the lifting column. 	Operator
	Defective spindle nut	<ul style="list-style-type: none"> Replace the lifting column. 	Qualified personnel
Markedly reduced speed	Obstacle in the lifting column's stroke area	<ul style="list-style-type: none"> Remove all obstacles from the stroke area. 	Operator
	Incorrect load	<ul style="list-style-type: none"> Remove load from the lifting column. 	Operator
	Motor, gears, or nuts faulty	<ul style="list-style-type: none"> Replace the lifting column. 	Qualified personnel
Significantly increased running noise	Obstacle in the lifting column's stroke area	<ul style="list-style-type: none"> Remove all obstacles from the stroke area. 	Operator
	Incorrect load	<ul style="list-style-type: none"> Remove load from the lifting column. 	Operator
	Motor, gears, or ball screw nuts faulty	<ul style="list-style-type: none"> Replace the lifting column. 	Qualified personnel

9.3 Startup after correcting a malfunction

Once the malfunction has been corrected:

- Before restarting, carry out the steps described in the Assembly and Commissioning sections.

10 Maintenance

Authorized personnel

- The measures described here may be carried out by the operator unless otherwise specified.
- Some tasks may only be carried out by qualified personnel; this will be explicitly stated in the description of the respective maintenance work.
- Work on the electrical system may only be carried out by trained, electrically skilled persons.

Safety instructions



Improper maintenance

Risk of electric shock. Improper maintenance can result in serious injury, death, or damage.

- Work on electrical systems may only be carried out by professional electricians.



Risk of fatal injury from unauthorized reconnection of the power supply

Risk of fatal injury to persons in the hazard area due to moving parts or electric shock if the power supply is switched on without authorization during work on the system and causes the system to restart.

- Before starting work, switch off the system and secure it against reconnection.



Schaeffler also recommends compliance with IEC 62353 with regard to maintenance.

10

10.1 Maintenance plan

The following sections describe the maintenance work required for optimum and trouble-free operation.

If increased wear is detected during regular inspections, shorten the maintenance intervals according to the actual signs of wear.



If the lifting column is used outside the ambient conditions specified previously in this manual, check the components once a month for changes such as oxidation or deposits.

8 Maintenance plan

Maintenance interval	Maintenance work	Carried out by
Daily	▸ Remove dust and dirt if necessary ▶42 10.2.1.	Operator
	▸ Check the lifting column for visible damage ▶43 10.2.4.	Qualified personnel
	▸ Check the lifting column for unusual noises or changes in performance.	
Monthly	▸ Check the lifting column for audible damage.	Operator
	▸ Check operating functions and safety functions ▶42 10.2.2.	Qualified personnel
	▸ Check that the device is securely fastened to the base plates; correct if necessary.	
	▸ Check connections for secure fit.	
Annually	▸ Check labels and warning notices for damage; replace if necessary.	Qualified personnel
	▸ Read protective conductor resistance ▶42 10.2.2.	Professional electrician
	▸ Read leakage currents ▶42 10.2.2.	
	▸ Read insulation resistance ▶42 10.2.2.	
	▸ Check plugs for secure fit.	

10.2 Maintenance work

10.2.1 Cleaning

To be performed by the operator

If contaminated, clean the product immediately to prevent the buildup of residue.

NOTICE



Damage due to improper cleaning

Improper cleaning of the device may cause damage to the device.

- Do not use aggressive cleaning agents. Wash water, including chemical additives, must be pH-neutral.
- Only use cleaning agents specified by the manufacturer.
- Do not use steam cleaners or high-pressure cleaners.
- Other cleaning agents or cleaning devices may only be used with the manufacturer's approval.
- When retracting or extending, the lifting column must not come into contact with liquids.

- ✓ Lifting column is installed in the application and correctly mounted.
 - ✓ Lifting column is protected against contact with liquids.
1. Disconnect the lifting column from the power supply.
 2. Clean the lifting column manually using a damp cloth and water. If necessary, add a small amount of isopropyl alcohol to the washing water.

10.2.2 Inspections and readings

To be performed by a qualified electrician

When carrying out inspections and measurements, observe the following:

- All inspections and measurements must be carried out in accordance with the applicable standards and regulations.
- All inspections and measurements must be documented in a maintenance log ►42 | 10.2.3.

Measuring the protective conductor resistance (TXG50, TXG90)

The external metal parts are not connected to the protective earth conductor, with the exception of the external protective conductor connection. The separation or insulation is achieved either by double or reinforced insulation or by an intermediate circuit that is connected to a protective earth conductor inside the housing.

For this reason, it is not possible to measure the protective conductor resistance.

10.2.3 Service log

Enter the following in the maintenance log:

- name of the executing body (company, department)
- names of the staff on duty
- identification of the device or system (type, serial number, inventory number) and the respective accessories
- completed inspections and measurements
- scope and results of the inspections

- measurement method, measuring device, measuring results of the readings
- overall assessment and verification of all functions compared to specifications
- date and signature of the person performing the inspection, personal encoding is possible for IT applications.

10.2.4 Visual inspection of the external condition

Performed by qualified personnel

1. Disconnect the device from the power supply and secure it against unintentional reconnection.
2. Check the cable for visible external damage such as cracks, cuts, and crushed sections.
3. Check the rim cover for visible external damage such as cracks, gaps, and fractures.
4. Check the guide tubes for visible external damage such as scratches and indentations.
5. If damage is found, notify the processor or the manufacturer.
6. If no damage is detected and neither the processor nor the manufacturer has raised concerns, reconnect the device to the power supply.

10

🔍 15 Visual inspection

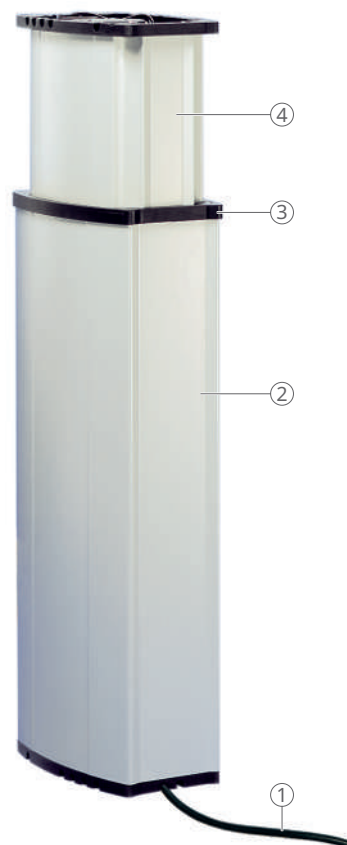

001C33A1

1	Cable	2	Outer tube
3	Rim cover	4	Inner tube

10.3 Measures following completed maintenance

After completing the maintenance work, carry out the following steps before recommissioning the device:

1. Check all previously loosened screw connections for a secure fit.
2. Ensure that all tools, materials, and other equipment used have been removed from the work area.
3. Clean the work area and remove any spilled liquids, process media, or similar substances.
4. Ensure that all of the system's safety measures are working correctly.
5. Check functions against the product specifications.
6. Document the inspections in the maintenance log.

11 Dismounting

Comply with all safety regulations.

Authorized personnel

- Disassembly may only be carried out qualified technical personnel.
- Work on the electrical system may only be carried out by trained, electrically skilled persons.

Safety instructions

DANGER



Risk of serious or fatal injuries from live components and moving parts

Serious or fatal injuries may result from contact with live components or from unexpected movement of the lifting column.

- Switch off the power supply and secure it against unintentional reconnection before performing any work on the system.

WARNING



Risk of severe injury from improper disassembly

Stored residual energy, sharp-edged components, pins, and corners on individual parts or on the required tools can cause severe injuries if disassembly is performed improperly.

- Ensure sufficient space for disassembly before starting work.
- Exercise caution when working with exposed, sharp-edged components.
- Ensure that the disassembly area is clean and tidy. Avoid loosely stacked components or parts and tools lying on the floor which may pose a hazard.
- Disassemble components properly in accordance with applicable local regulations.
- Secure components to prevent them from falling or tipping over.
- Contact Schaeffler with any questions or concerns.

Removing the lifting column

1. Disconnect the device from the power supply or external control unit.
2. Disconnect the device from all other connections (operating element, electrical anti-pinching protection, master-slave lifting column, etc.).
3. Secure the application elements so that no pull or push forces act on the device.
4. Removing the lifting column from the application:
5. Loosen and remove the fastening screws.
6. Disconnect the lifting column from the fastening points in the application.
7. Clean the device
8. Carefully pack the device for shipping to the manufacturer.
9. Disassemble the device in accordance with locally applicable occupational safety and environmental protection regulations.

12 Disposal

If no return or disposal agreement is in place, disassembled components must be recycled.

CAUTION



Improper disposal

environmental damage

- Electronic waste, electronic components, lubricants, and other additives are subject to hazardous waste regulations and may only be disposed of by authorized specialist companies.

Observe the local regulations for disposal.

For information on environmentally sound disposal, contact your local authorities or specialist companies.

1. Dispose of metal and plastic parts at an appropriate recycling facility.
2. Sort remaining components by material and dispose of them in accordance with locally applicable occupational safety and environmental protection regulations.

13 Technical data

For detailed and current information on equipment and operating data:



LA 1 | Lifting and Actuating Systems |
<https://www.schaeffler.de/std/222A>

For further information, contact Schaeffler.

Standard: IEC 60601-1

9 Technical data TXG

Feature	Unit	TXG10	TXG40, TXG50	TXG80, TXG90
Rated push force	N	1500	1500	1500
Rated pull force	N	0	0	0
Offset load	Nm	≤ 210 ¹⁾	≤ 210 ¹⁾	≤ 210 ¹⁾
Speed (full load to no load)	mm/s	17 ... 23	17 ... 23	17 ... 23
Lifting column version (number of guide tubes)	-	2-part	2-part	2-part
Stroke S	mm	200 ... 600	200 ... 600	200 ... 600
Retracted length L	mm	S + 180	S + 180	S + 180
Voltage	V	DC 24 V	AC 120 V	AC 230 V
Mains frequency	Hz	-	50 ... 60	50 ... 60
Current consumption	A	5	1.8	0.9
Duty cycle, intermittent operation	min	ON: 1 min / OFF: 9 min	ON: 1 min / OFF: 9 min	ON: 1 min / OFF: 9 min
Ambient temperature during operation	°C	+10 ... +40	+10 ... +40	+10 ... +40
	°F	+50 ... +104	+50 ... +104	+50 ... +104
Protection code (IP)	-	IP30	IP30	IP30
Protection class IEC 61140	-	III (SELV)	II / (I) ²⁾	II / (I) ²⁾
Type of actuation	-	Electrical	Electrical	Electrical
Mass	kg	8 ... 13	9 ... 14	9 ... 14

¹⁾ for details, see bending load diagram

²⁾ mandatory for cable feed through

10 Suitable control units and operating elements for TXG10

Operating element		Control unit
Designation	Switch	COMPACT
HSM	T	✓
HSF	T	✓

T Desk switch

✓ suitable

11 Suitable operating elements for TXG40, TXG50, TXG80, TXG90

Operating element		Lifting columns (with integrated control unit)			
Designation	Switch	TXG40	TXG50	TXG80	TXG90
EHE1	M	✓	✓	✓	✓
STF	F	✓	✓	✓	✓
STA	T	✓	✓	✓	✓

M Hand switch

F Foot switch

T Desk switch

✓ suitable

- air pressure: 700 hPa to 1060 hPa
- max. altitude above sea level: 3000 m (MOPP)
- supply network with overvoltage category I
- pollution degree 2
- no strong radiation fields

13.2 Type plate

The type plate contains the following information:

17 Product label TXG



001C33B1

1	Type key	2	Electricity consumption
3	Serial number	4	Duty cycle (ON/OFF)
5	Quality mark	6	See accompanying documents
7	Date of manufacture MM.YY	8	Stroke length and speed
9	Push force		

13.3 Plans and diagrams

18 Connecting diagram DC 24 V

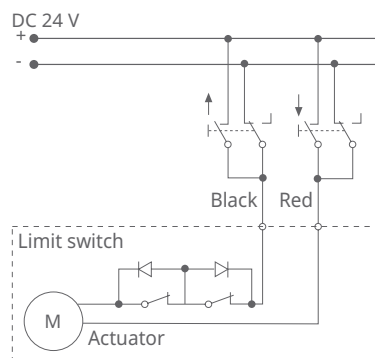

001DEE03

19 Connecting diagram AC 120 V, AC 230 V

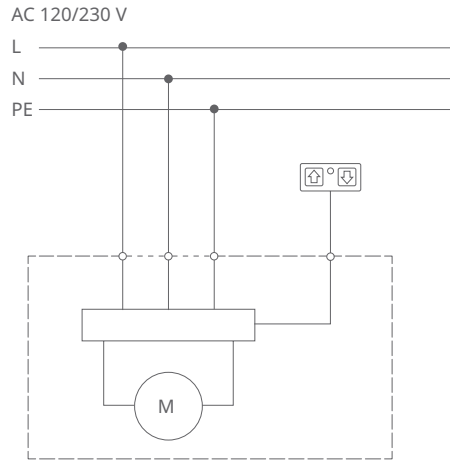

001C319D

20 Speed-load diagram

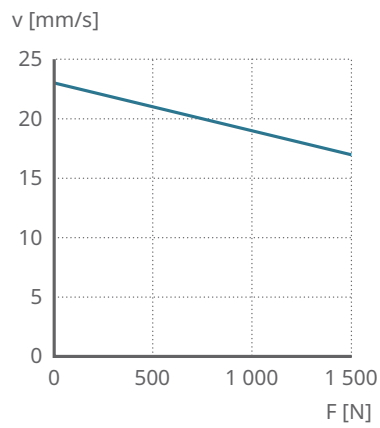

001C319F

v Speed | F Load

21 Offset load diagram TXG

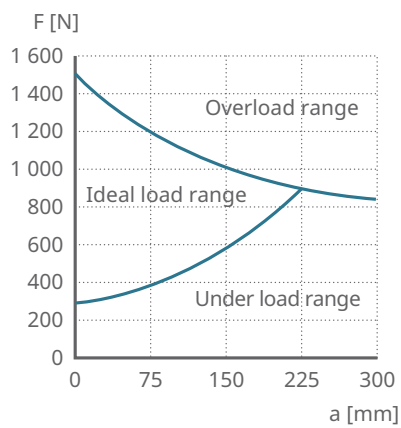

001C33C1

F Load | a Load distance from center of column

22 Safety factor under load conditions

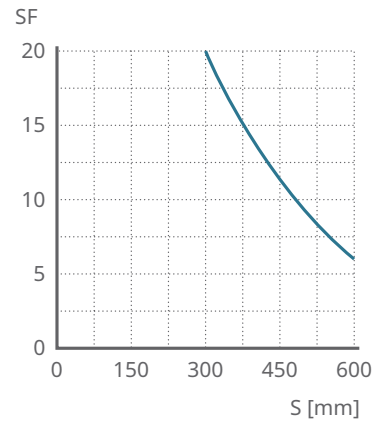

001C31A3

SF Safety factor

S Stroke

13.4 Declaration of incorporation

TXG |

<https://www.schaeffler.de/std/2273>

14 Replacement parts and accessories

14.1 Replacement parts

Spare parts not included in the scope of delivery.

12 Replacement parts

Designation		Ordering designation	Order number
Connection cable	1 m	ZKA-306-355-1000	0121741
Connection cable	2.5 m	ZKA-306-355-2500	0121742

If you require additional information or replacement parts, please contact Schaeffler.

14.2 Accessories

13 Accessories

Designation	Plug	Country	Order number	Comments
Mains cable, straight, 3 m	Euro	General	0121730	2-pin
Mains cable, straight, 3 m	Schuko	General	0121729	3-pin
Mains cable, straight, 3 m	SEV	CH	0128699	3-pin
Mains cable, straight, 3 m	UL	USA	0126322	2-pin
Mains cable, straight, 3 m	UL	USA	0121762	3-pin
Upper or lower mounting plate	-	-	0124874	-

Fastening screws are included with the lifting column.

Schaeffler Technologies AG & Co. KG

Georg-Schäfer-Straße 30

97421 Schweinfurt

Germany

www.schaeffler.de/en

info.de@schaeffler.com

In Germany:

Phone 0180 5003872

From other countries:

Phone +49 9721 91-0

All information has been carefully compiled and checked by us, but we cannot guarantee complete accuracy. We reserve the right to make corrections. Therefore, please always check whether more up-to-date or amended information is available. This publication supersedes all deviating information from older publications. Printing, including excerpts, is only permitted with our approval.
© Schaeffler Technologies AG & Co. KG
BA 121 / 01 / en-US / 2026-04