

Axial/Radial Bearings

YRTA

Product Data Sheet

1 Axial/radial bearings

Axial/radial bearings YRTA, YRTC and YRTS are ready-to-fit high precision bearings capable of supporting radial loads, axial loads from both sides and tilting moments without clearance. They are very rigid, have a high load carrying capacity, and run with high accuracy.

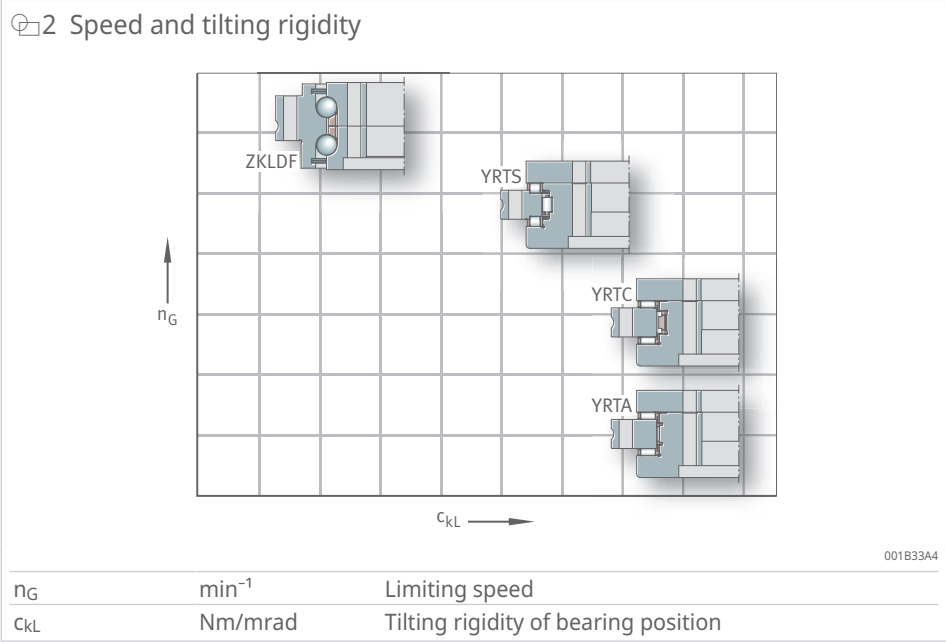
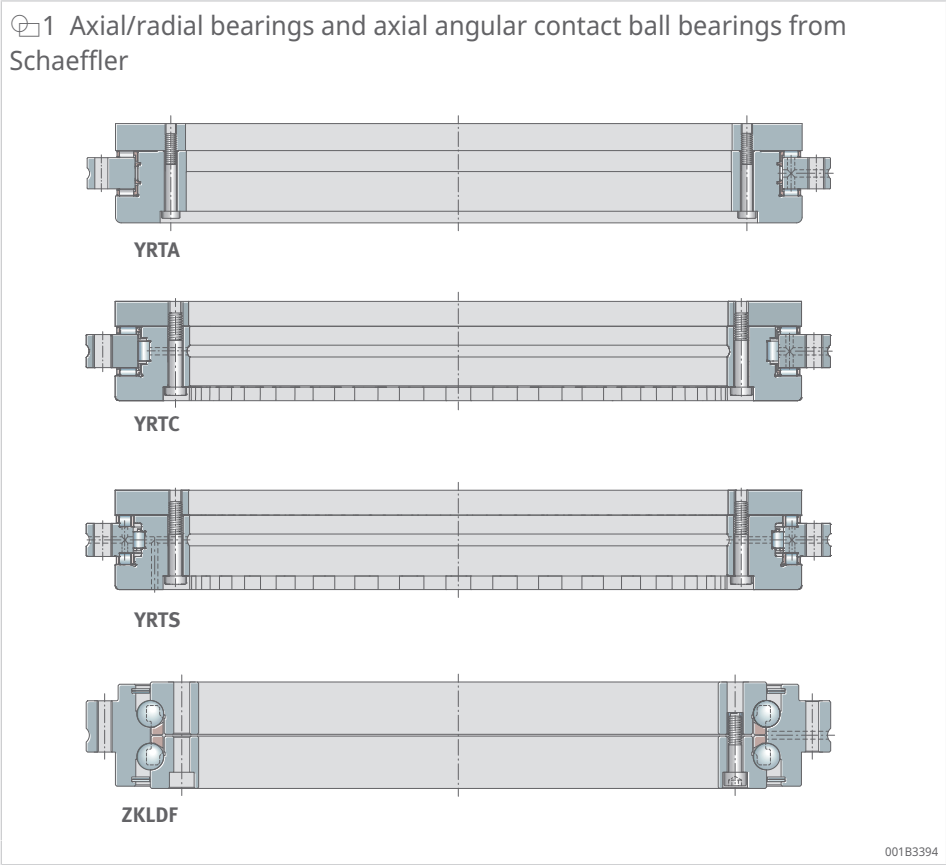

2 Bearing design

In terms of their fundamental design, the bearings in the YRTA series are based on the proven three-row YRTC roller bearing design and have been specifically optimised to meet the requirements of automation applications. The bearing is also suitable for classic driven rotary tables. YRTA axial/radial bearings offer the technical advantages of the proven YRTC concept, which have been adapted not only for applications in machine tool peripherals but also for applications in productronics and classic swivelling rotary tables with low accuracy requirements.

3 Adapted internal construction of series YRTA

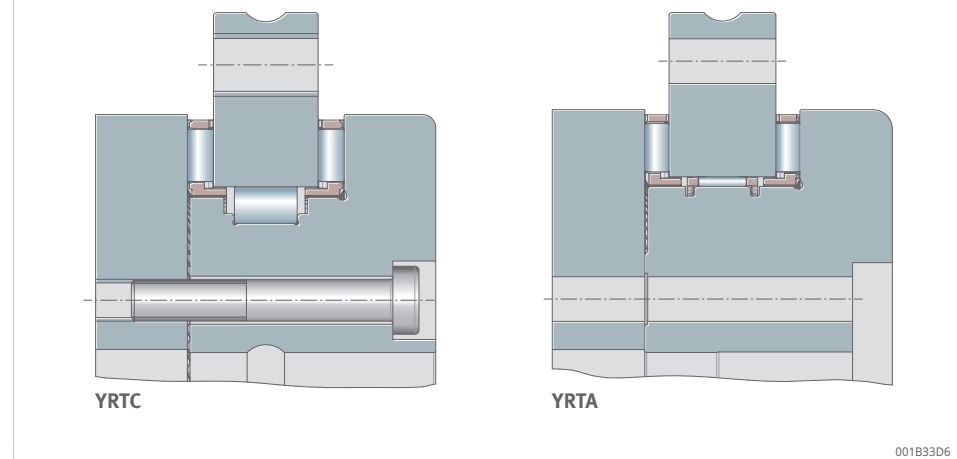

Axial/radial bearings YRTA

- high precision and tilting rigidity for swivel applications with low dynamics
- cost-optimised solution for rotary axes, not just for machine tools
- applications include pallet changers and rotary storage systems

4 Axial/radial bearings YRTA

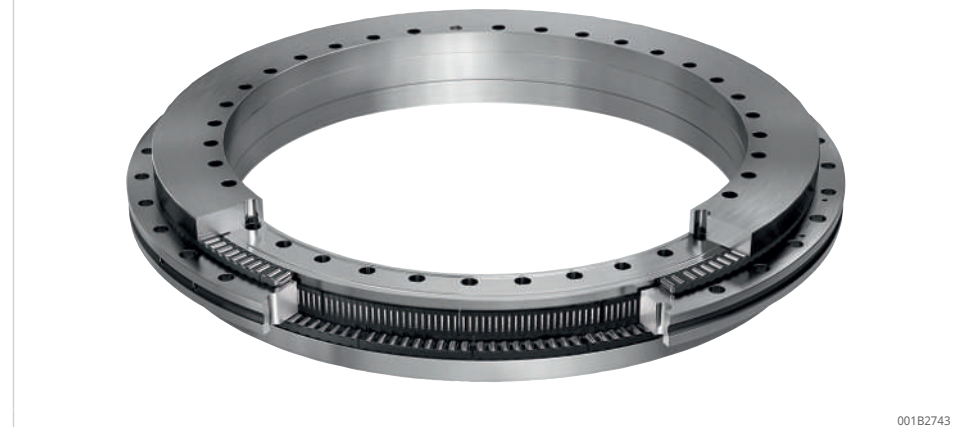

The bearings in the YRTA series have a radial cage. Due to the fixing holes in the bearing rings, mounting of the units is very simple.

3 Lubrication

Axial/radial bearings YRTA are supplied already greased and can be relubricated using Arcanol MULTITOP lubricating grease.

4 Sealing

Axial/radial bearings are not sealed.

Axial/radial bearings in the YRTA series are also optionally available as capped variants with a sheet metal gap seal on both sides. This reduces the ingress of dust in automation applications.

5 Speeds

Axial/radial bearings YRTA are designed for swivel-type operation.

The limiting speeds provided in the product tables must be observed ►10 | 14.

6 Rigidity

The product tables give the rigidity values for the complete bearing position. These take account of the deflection of the rolling element set as well as the deformation of the bearing rings and the screw connections ►10 | 14.

7 Temperature range

Axial/radial bearings and axial angular contact ball bearings are suitable for operating temperatures from -30 °C to +100 °C.

8 Internal clearance

Once the bearings have been fitted and fully screw mounted, they are radially and axially clearance-free and preloaded.

YRTA bearings are supplied with a defined preload, ensuring uniform frictional torque and a high tilting rigidity. This allows the bearings to run smoothly, thus also rendering them suitable for manually operated swivel tables.

9 Dimensions, tolerances

The tolerances for the main dimensions correspond to tolerance class 6 in accordance with ISO 492 (DIN 620-2).

The tolerances for concentricity and axial runout accuracy can be found in the dimensional tolerances.

1 Dimensional tolerances

d	t _{Δdmp}		D	t _{ΔDmp}	
	U	L		U	L
mm	mm	mm	mm	mm	mm
50	0	-0,008	126	0	-0,011
80	0	-0,009	146	0	-0,011
100	0	-0,01	185	0	-0,015
120	0	-0,01	210	0	-0,015
150	0	-0,013	240	0	-0,015
180	0	-0,013	280	0	-0,018
200	0	-0,015	300	0	-0,018
260	0	-0,018	385	0	-0,02
325	0	-0,023	450	0	-0,023
395	0	-0,023	525	0	-0,028
460	0	-0,023	600	0	-0,028
580	0	-0,025	750	0	-0,035
650	0	-0,038	870	0	-0,05

d	mm	Bore diameter
D	mm	Outside diameter
L	mm	Lower limit deviation
t _{Δdmp}	mm	Deviation of the mean value of the bore diameter from the nominal size in accordance with ISO 492
t _{ΔDmp}	mm	Deviation of the mean value of the outside diameter from the nominal size in accordance with ISO 492
U	mm	Upper limit deviation

The geometrical and positional tolerances correspond to tolerance class 4 in accordance with ISO 492 (DIN 620-2).

2 Mounting dimensions, axial runout and radial runout

d	H ₁	t _{ΔH1s}		H ₂	t ₁ ¹⁾
		U	L		
mm	mm	mm	mm	mm	μm
50	20	0,025	-0,025	10	2
80	23,35	0,025	-0,025	11,7	3
100	25	0,025	-0,025	13	3
120	26	0,025	-0,025	14	3
150	26	0,03	-0,03	14	3
180	29	0,03	-0,03	14	4
200	30	0,03	-0,03	15	4
260	36,5	0,04	-0,04	18,5	6
325	40	0,05	-0,05	20	6
395	42,5	0,05	-0,05	22,5	6
460	46	0,06	-0,06	24	6
580	60	0,25	-0,25	30	10
650	76	0,25	-0,25	44	10

1) for rotating inner ring and rotating outer ring

d	mm	Bore diameter
H ₁	mm	Contact surface height, outer ring
H ₂	mm	Contact surface height, outer ring
L	mm	Lower limit deviation
t _{ΔH1s}	mm	Deviation of height from nominal size in accordance with ISO 492
t _{ΔH2s}	mm	Deviation of height from nominal size in accordance with ISO 492
t ₁	μm	Axial and radial runout, measured on fitted bearing with ideal adjacent construction
U	mm	Upper limit deviation

10 Structure of the ordering designation

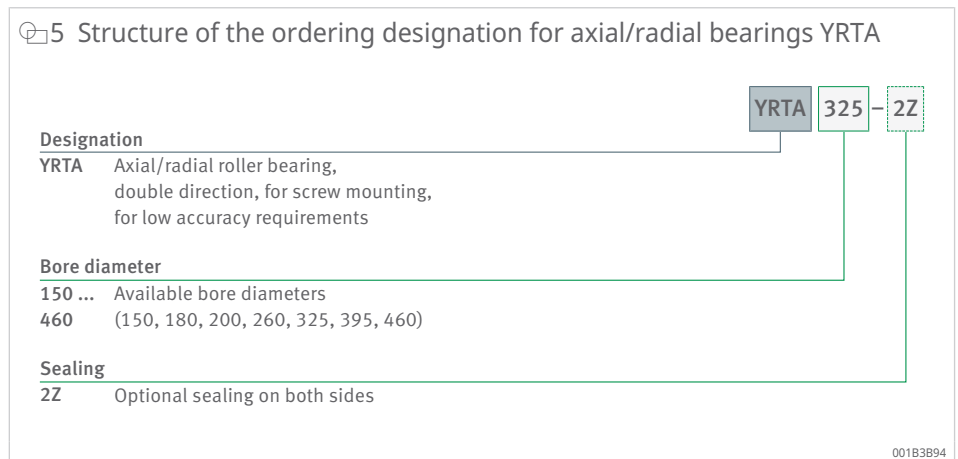

11 Dimensioning

11.1 Static load safety factor

The static load safety factor S_0 indicates the security against impermissible permanent deformations in the bearing.

! In machine tools and similar areas of application, S_0 should be > 4 .

11.2 Static limiting load diagrams

The static limiting load diagram can be used for the following purposes:

- rapid checking of the selected bearing size under predominantly static load
- calculation of the tilting moment M_k that can be supported by the bearing in addition to the axial load

The static limiting load diagram takes into account a static load safety factor $S_0 \geq 4$ for the rolling element set, as well as the strength of the screws and the bearing ring.

! The static limiting load must not be exceeded when dimensioning the bearing arrangement.

6 Static limiting load diagram for YRTA150 to YRTA200

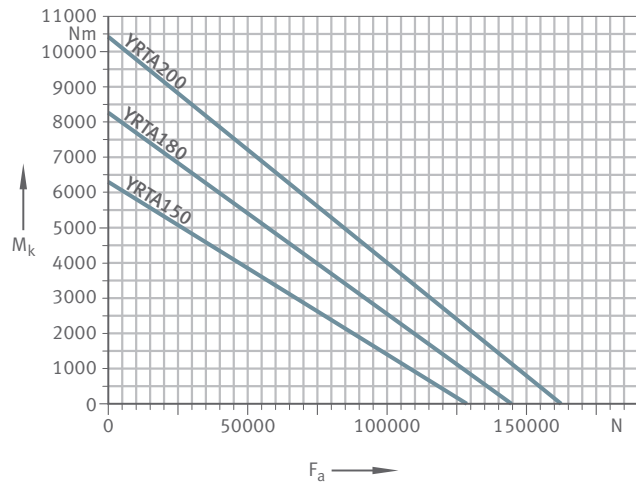

001833FA

M_k	Nm	Max. tilting moment
F_a	N	Axial load

7 Static limiting load diagram for YRTA260 to YRTA460

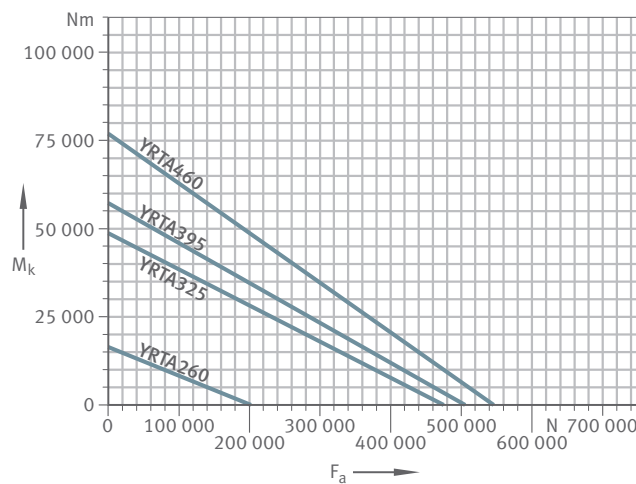

0018340A

M_k	Nm	Max. tilting moment
F_a	N	Axial load

11.3 Frictional torque

The guide values for the frictional torques for axial/radial bearings were determined at a measurement speed $n = 5 \text{ min}^{-1}$.

12 Design of the adjacent construction

The hole pattern for the YRTA series corresponds to the hole pattern for the YRTC series, however, the fixing holes in the inner ring do not have individual countersunk holes. The countersunk holes are replaced by a circumferential undercut.

- ! Geometrical defects in the screw mounting surfaces and fits will influence the running accuracy, preload and running characteristics of the bearing arrangement. The accuracy of the adjacent surfaces must therefore be matched to the accuracy requirement of the entire assembly.

Design adjacent construction in accordance with the requirements for the adjacent construction ►9|8.

8 Requirements for the adjacent construction

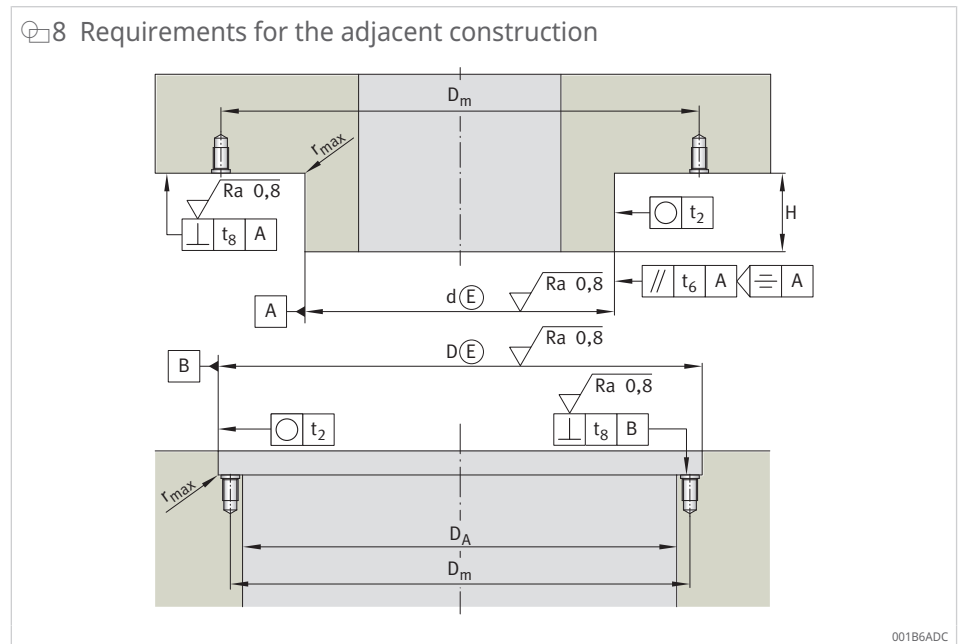

Maintain tolerances according to required geometrical and positional accuracy. Any deviations from the specified tolerances will influence the bearing frictional torque, running accuracy and running characteristics.

12.1 Fits

The selection of fits leads to transition fits, i.e. depending on the actual dimensional position of the bearing diameter and mounting dimensions, clearance fits or interference fits can arise.

13 Further information

Further information can be found in the following publications:

TPI 120 | High Precision Bearings for Combined Loads |

<https://www.schaeffler.de/std/200D>

14 Product tables

14.1 Explanations of the product tables

1	-	Two retaining screws
a	mm	Countersink depth
C	mm	Outer ring width
C _{0a}	N	Basic static load rating, axial
C _{0r}	N	Basic static load rating, radial
C _a	N	Basic dynamic load rating, axial
C _{aL}	N/μm	Axial rigidity of bearing position
C _{aW}	N/μm	Axial rigidity of rolling element set
C _{kL}	Nm/mrad	Tilting rigidity of bearing position
C _{kW}	Nm/mrad	Tilting rigidity of rolling element set
C _r	N	Basic dynamic load rating, radial
C _{rL}	N/μm	Radial rigidity of bearing position
C _{rW}	N/μm	Radial rigidity of rolling element set
d	mm	Bore diameter
D	mm	Outside diameter
d ₁	mm	Diameter of fastening hole, inner ring
D ₁	mm	Inner ring diameter
D ₂	mm	Diameter of undercut
d ₃	mm	Diameter of fixing holes, outer ring
G	-	Extraction threads
H	mm	Height
H ₁	mm	Contact surface height, outer ring
H ₂	mm	Contact surface height, outer ring
J	mm	Pitch circle diameter of fixing holes, inner ring
J ₁	mm	Pitch circle diameter of fixing holes, outer ring
m	kg	Mass
M _A	Nm	Tightening torque for fixing screws according to DIN EN ISO 4762, strength class 10.9
M _R	Nm	Frictional torque
n	-	Number of screw mounting holes
n _A	-	Number of fixing screws, outer ring
n _G	min ⁻¹	Limiting speed
n _{GA}	-	Number of extraction threads
n _I	-	Number of fixing screws, inner ring
t	°	Pitch angle of fixing holes

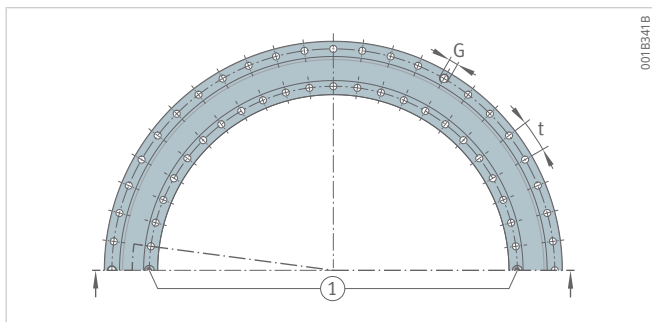

Hole pattern

C_a	C_{0a}	C_r	C_{0r}	n_G	M_R
N	N	N	N	min^{-1}	Nm
56000	280000	9500	24300	440	3,5
38000	158000	11400	34000	350	4,5
93000	455000	21500	68000	280	4,5
99000	520000	21700	73000	230	6
113000	650000	23300	83000	210	8
119000	730000	24500	94000	190	9
130000	850000	28000	115000	170	11
149000	1090000	31500	147000	130	17
219000	1900000	46000	255000	110	24
234000	2190000	51000	305000	90	35
255000	2550000	55000	355000	80	45
510000	4450000	116000	720000	60	90
810000	6800000	119000	780000	55	105

14.3 YRTA, mounting dimensions, rigidity values

Double direction
For automation

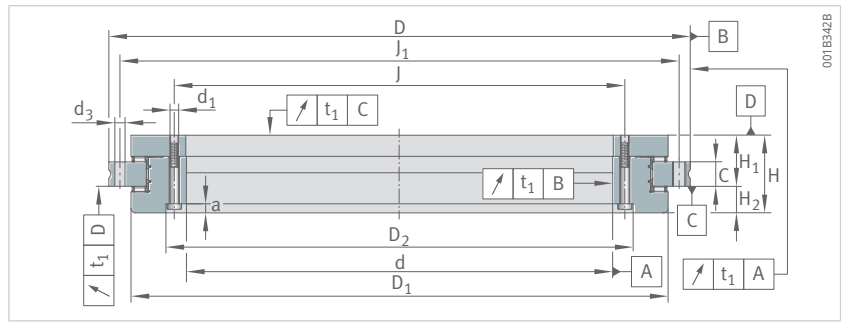

YRTA

Designation	d ₁	D ₂	a	n _I	d ₃	n _A	M _A
-	mm	mm	mm	-	mm	-	Nm
YRTA50	5,6	-	-	10	5,6	12	8,5
YRTA80	5,6	102	4	10	4,6	12	8,5
YRTA100	5,6	122	5,4	16	5,6	15	8,5
YRTA120	7	146	6,2	22	7	21	14
YRTA150	7	176,6	6,2	34	7	33	14
YRTA180	7	205,6	6,2	46	7	45	14
YRTA200	7	226,6	6,2	46	7	45	14
YRTA260	9,3	295,8	8,2	34	9,3	33	34
YRTA325	9,3	357,8	8,2	34	9,3	33	34
YRTA395	9,3	430,8	8,2	46	9,3	45	34
YRTA460	9,3	497,8	8,2	46	9,3	45	34
YRTA580	11,4	628	11	46	11,4	42	68
YRTA650	14	700	13	46	14	42	116

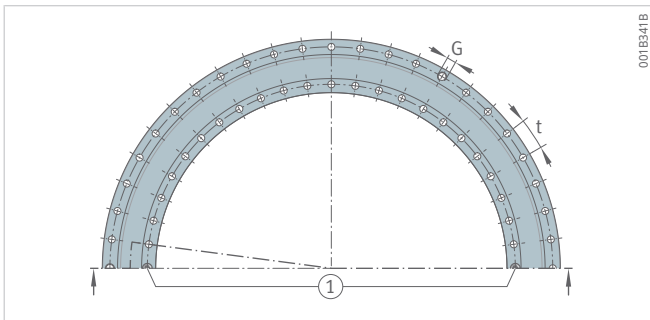

Hole pattern

n	t	G	n _{GA}	C _{aL}	C _{rL}	C _{kL}	C _{aW}	C _{rW}	C _{kW}
-	°	-	-	N/μm	N/μm	Nm/mrad	N/μm	N/μm	Nm/mrad
12	30	-	-	2600	1540	2037,5	6200	2100	5400
12	30	-	-	3200	2520	4075	4000	3600	5800
18	20	M5	3	5300	3150	12200	8700	5200	23500
24	15	M8	3	5800	3640	18200	9800	5600	35500
36	10	M8	3	7600	4480	30300	12000	6500	61000
48	7,5	M8	3	9400	5000	46000	13500	7700	88500
48	7,5	M8	3	9800	5700	64000	15500	10000	128000
36	10	M12	3	13800	7400	166000	19000	12000	265000
36	10	M12	3	14200	8800	254000	33000	20000	633000
48	7,5	M12	3	19800	8100	448000	37000	25000	1002000
48	7,5	M12	3	24000	9100	686000	43000	30000	1543000
48	7,5	M12	6	23800	4100	1176000	41800	37500	2570000
48	7,5	M12	6	41200	10200	1909000	52000	38500	3879000

Schaeffler Technologies AG & Co. KG

Georg-Schäfer-Straße 30

97421 Schweinfurt

Germany

www.schaeffler.de/en

info.de@schaeffler.com

In Germany:

Phone 0180 5003872

From other countries:

Phone +49 9721 91-0

All information has been carefully compiled and checked by us, but we cannot guarantee complete accuracy. We reserve the right to make corrections. Therefore, please always check whether more up-to-date or amended information is available. This publication supersedes all deviating information from older publications. Printing, including excerpts, is only permitted with our approval.
© Schaeffler Technologies AG & Co. KG
PDB 76 / 02 / en-GB / 2026-01